





# Pro-Finish® Cabinet Models

## Pro-Finish® Cabinets (Pressure Systems)

MODEL DESCRIPTION	PART NUMBER	NUMBER OF DOORS	DUST COLLECTION	BLOWER MOTOR	SHIPPING WEIGHT
2636 PR-4	142101	1 standard	—	—	615 lbs
2636 PRB-4	102100	1 standard	Dust bag	1 hp	664 lbs
2636 PRC-4	102101	1 standard	DCM-80A	1 hp	914 lbs
2636 PR-6	142142	1 standard	—	—	630 lbs
2636 PRC-6	102142	1 standard	DCM-200	1 hp	1345 lbs
2636 PRC-6, CDC	102148	1 standard	CDC-6	1½ hp	1465 lbs
3648 PR-4	143101	2 standard	—	—	735 lbs
3648 PRB-4	103100	2 standard	Dust bag	1 hp	782 lbs
3648 PRC-4	103101	2 standard	DCM-80A	1 hp	1032 lbs
3648 PR-6	143121	2 standard	—	—	750 lbs
3648 PRC-6	103121	2 standard	DCM-200	1½ hp	1479 lbs
3648 PRC-6, CDC	103151	2 standard	CDC-6	1½ hp	1779 lbs
3660 PR-6	146102	2 standard	—	—	1180 lbs
3660 PRC-6	126101	2 standard	DCM-200	1½ hp	1910 lbs
3660 PRC-6, CDC	126151	2 standard	CDC-6	1½ hp	2030 lbs
3660 PR-9	146121	2 standard	—	—	1215 lbs
3660 PRC-9	126121	2 standard	DCM-200A	2 hp	1945 lbs
3660 PRC-9, CDC	126152	2 standard	CDC-9	2 hp	2065 lbs
3674 PRC-9	128121	2 standard	DCM-200A	2 hp	1970 lbs
3674 PRC-9, CDC	128151	2 standard	CDC-9	2 hp	2290 lbs
3696 TWIN PRB-4	106100	2 standard	(2) Dust bags	(2) 1 hp	1379 lbs
3696 TWIN PRC-4	106101	2 standard	(2) DCM-80A	(2) 1 hp	1879 lbs
3696 TWIN PRC-6	106121	2 standard	(2) DCM-200	(2) 1½ hp	2773 lbs
3696 TWIN PRC-6, CDC	106151	2 standard	(2) CDC-6	(2) 1½ hp	3373 lbs
4848 PR-6	144101	2 standard	—	—	910 lbs
4848 PRC-6	104101	2 standard	DCM-200	1½ hp	1636 lbs
4848 PRC-6, CDC	104151	2 standard	CDC-6	1½ hp	1936 lbs
4848 PR-9	144121	2 standard	—	—	940 lbs
4848 PRC-9	104121	2 standard	DCM-200A	2 hp	1671 lbs
4848 PRC-9, CDC	104152	2 standard	CDC-9	2 hp	1791 lbs
6060 PR-9	145101	2 standard	—	—	1219 lbs
6060 PRC-9	105101	2 standard	DCM-200A	2 hp	1949 lbs
6060 PRC-9, CDC	105151	2 standard	CDC-9	2 hp	2069 lbs
60120 TWIN PRC-9	107101	2 standard	DCM-200A	(2) 2 hp	3713 lbs
60120 TWIN PRC-9, CDC	107151	2 standard	CDC-9	(2) 2 hp	4313 lbs
7272 PRC-9	127101	1 standard	DCM-200A	2 hp	2900 lbs
7272 PRC-12	127123	1 standard	DCM-200B	5 hp	3000 lbs



# Pro-Finish® Cabinet Models

## Pro-Finish® Cabinets (Suction Systems)

MODEL DESCRIPTION	PART NUMBER	NUMBER OF DOORS	DUST COLLECTION	BLOWER MOTOR	SHIPPING WEIGHT
2636 S	142011	1 standard	—	—	370 lbs
2636 SB	102010	1 standard	Dust bag	1 hp	421 lbs
2636 SC	102011	1 standard	DCM-80A	1 hp	671 lbs
2636 SR-4	142001	1 standard	—	—	400 lbs
2636 SRB-4	102000	1 standard	Dust bag	1 hp	451 lbs
2636 SRC-4	102001	1 standard	DCM-80A	1 hp	701 lbs
2636 SR-6	142021	1 standard	—	—	440 lbs
2636 SRC-6	102021	1 standard	DCM-200	1½ hp	1130 lbs
2636 SRC-6, CDC	102041	1 standard	CDC-6	1½ hp	1250 lbs
3648 S	143011	2 standard	—	—	490 lbs
3648 SB	103010	2 standard	Dust bag	1 hp	539 lbs
3648 SC	103011	2 standard	DCM-80A	1 hp	789 lbs
3648 SR-4	143001	2 standard	—	—	520 lbs
3648 SRB-4	103000	2 standard	Dust bag	1 hp	565 lbs
3648 SRC-4	103001	2 standard	DCM-80A	1 hp	819 lbs
3648 SR-6	143021	2 standard	—	—	560 lbs
3648 SRC-6	103021	2 standard	DCM-200	1½ hp	1266 lbs
3648 SRC-6, CDC	103051	2 standard	CDC-6	1½ hp	1575 lbs
3660 S	146011	2 standard	—	—	940 lbs
3660 SC	126011	2 standard	DCM-200	1½ hp	1670 lbs
3660 SR-6	146001	2 standard	—	—	965 lbs
3660 SRC-6	126001	2 standard	DCM-200	1½ hp	1695 lbs
3660 SRC-6, CDC	126051	2 standard	CDC-6	1½ hp	1815 lbs
3660 SR-9	146021	2 standard	—	—	1000 lbs
3660 SRC-9	126021	2 standard	DCM-200A	2 hp	1730 lbs
3660 SRC-9, CDC	126052	2 standard	CDC-9	2 hp	1850 lbs
3674 SRC-9	128021	2 standard	DCM-200A	2 hp	1760 lbs
3674 SRC-9 (CDC)	128051	2 standard	CDC-9	2 hp	2060 lbs
3696 TWIN SB	106010	2 standard	(2) Dust bags	(2) 1 hp	1078 lbs
3696 TWIN SC	106011	2 standard	(2) DCM-80A	(2) 1 hp	1578 lbs
3696 TWIN SRB-4	106000	2 standard	(2) Dust bags	(2) 1 hp	1138 lbs
3696 TWIN SRC-4	106001	2 standard	(2) DCM-80A	(2) 1 hp	1638 lbs
3696 TWIN SRC-6	106021	2 standard	(2) DCM-200	(2) 1½ hp	2632 lbs
3696 TWIN SRC-6, CDC	106051	2 standard	(2) CDC-6	(2) 1½ hp	3232 lbs
4848 S	144011	2 standard	—	—	670 lbs
4848 SC	104011	2 standard	DCM-200	1½ hp	1400 lbs
4848 SR-6	144001	2 standard	—	—	695 lbs
4848 SRC-6	104001	2 standard	DCM-200	1½ hp	1423 lbs
4848 SRC-6, CDC	104051	2 standard	CDC-6	1½ hp	1545 lbs
4848 SR-9	144021	2 standard	—	—	730 lbs
4848 SRC-9	104021	2 standard	DCM-200A	2 hp	1458 lbs
4848 SRC-9, CDC	104052	2 standard	CDC-9	2 hp	1580 lbs
6060 S	145011	2 standard	—	—	939 lbs
6060 SC	105011	2 standard	DCM-200A	2 hp	1669 lbs
6060 SR-9	145001	2 standard	—	—	1006 lbs
6060 SRC-9	105001	2 standard	DCM-200A	2 hp	1736 lbs
6060 SRC-9, CDC	105051	2 standard	CDC-9	2 hp	1856 lbs
60120 TWIN SC	107011	2 standard	DCM-200A	(2) 2 hp	3338 lbs
60120 TWIN SRC-9	107001	2 standard	DCM-200A	(2) 2 hp	3472 lbs
60120 TWIN SRC-9, CDC	107051	2 standard	CDC-9	(2) 2 hp	4072 lbs
7272 SRC-9	127001	1 standard	DCM-200A	2 hp	2700 lbs
7272 SRC-12	127023	1 standard	DCM-200B	5 hp	2800 lbs



# Pro-Finish® Cabinet Models

## Ergo-Blast Cabinets (Pressure Systems)

MODEL DESCRIPTION	PART NUMBER	NUMBER OF DOORS	DUST COLLECTION	BLOWER MOTOR	SHIPPING WEIGHT
ERGO 2636 PRC-4	120101	1 standard	DCM-80A	1 hp	1015 lbs
ERGO 3648 PRC-4	121101	2 standard	DCM-80A	1 hp	1130 lbs
ERGO 3648 PRC-6	121121	2 standard	DCM-200	1½ hp	1585 lbs
ERGO 3648 PRC-6, CDC	121151	2 standard	CDC-6	1½ hp	1885 lbs
ERGO FaStrip® 3648 PRC-6	121921	2 standard	DCM-200	1½ hp	1600 lbs
ERGO FaStrip® 3648 PRC-6, CDC	121951	2 standard	CDC-6	1½ hp	1900 lbs
ERGO 3660 PRC-6	123101	2 standard	DCM-200	1½ hp	2010 lbs
ERGO 3660 PRC-6, CDC	123151	2 standard	CDC-6	1½ hp	2130 lbs
ERGO 3660 PRC-9	123121	2 standard	DCM-200A	2 hp	2045 lbs
ERGO 3660 PRC-9, CDC	123152	2 standard	CDC-9	2 hp	2165 lbs
ERGO FaStrip® 3660 PRC-9	123921	2 standard	DCM-200A	2 hp	2120 lbs
ERGO FaStrip® 3660 PRC-9, CDC	123951	2 standard	CDC-9	2 hp	2240 lbs
ERGO 3696 TWIN PRC-4,	124101	2 standard	(2) DCM-80A	(2) 1 hp	2975 lbs
ERGO 3696 TWIN PRC-6	124121	2 standard	(2) DCM-200	(2) 1½ hp	2900 lbs
ERGO 3696 TWIN, PRC-6, CDC	124151	2 standard	(2) CDC-6	(2) 1½ hp	3500 lbs
ERGO 4848 PRC-6	122101	2 standard	DCM-200	1½ hp	1735 lbs
ERGO 4848 PRC-6, CDC	122151	2 standard	CDC-6	1½ hp	2035 lbs
ERGO 4848 PRC-9	122121	2 standard	DCM-200A	2 hp	1775 lbs
ERGO 4848 PRC-9, CDC	122152	2 standard	CDC-9	2 hp	2075 lbs
ERGO FaStrip® 4848 PRC-9	122921	2 standard	DCM-200A	2 hp	1800 lbs
ERGO FaStrip® 4848 PRC-9, CDC	122951	2 standard	CDC-9	2 hp	2050 lbs
ERGO 6060 PRC-9	125121	2 standard	DCM-200A	2 hp	2049 lbs
ERGO 6060 PRC-9, CDC	125152	2 standard	CDC-9	2 hp	2168 lbs
ERGO FaStrip® 6060 PRC-9	125921	2 standard	DCM-200A	2 hp	2074 lbs
ERGO FaStrip® 6060 PRC-9, CDC	125951	2 standard	CDC-9	2 hp	2193 lbs

## Ergo-Blast Cabinets (Suction Systems)

MODEL DESCRIPTION	PART NUMBER	NUMBER OF DOORS	DUST COLLECTION	BLOWER MOTOR	SHIPPING WEIGHT
ERGO 2636 SRC-4	120001	1 standard	DCM-80A	1 hp	800 lbs
ERGO 3648 SRC-4	121001	2 standard	DCM-80A	1 hp	920 lbs
ERGO 3648 SRC-6	121021	2 standard	DCM-200	1½ hp	1365 lbs
ERGO 3648 SRC-6, CDC	121051	2 standard	CDC-6	1½ hp	1665 lbs
ERGO 3660 SRC-6	123001	2 standard	DCM-200	1½ hp	1797 lbs
ERGO 3660 SRC-6, CDC	123051	2 standard	CDC-6	1½ hp	1917 lbs
ERGO 3660 SRC-9	123021	2 standard	DCM-200A	2 hp	1832 lbs
ERGO 3660 SRC-9, CDC	123052	2 standard	CDC-9	2 hp	1952 lbs
ERGO TWIN 3696 SRC-4,	124001	2 standard	(2) DCM-80A	(2) 1 hp	1840 lbs
ERGO TWIN 3696 SRC-6	124021	2 standard	(2) DCM-200	(2) 1½ hp	2850 lbs
ERGO TWIN 3696 SRC-6, CDC	124051	2 standard	(2) CDC-6	(2) 1½ hp	3450 lbs
ERGO 4848 SRC-6	122001	2 standard	DCM-200	1½ hp	1525 lbs
ERGO 4848 SRC-6, CDC	122051	2 standard	CDC-6	1½ hp	1825 lbs
ERGO 4848 SRC-9	122021	2 standard	DCM-200A	2 hp	1566 lbs
ERGO 4848 SRC-9, CDC	122052	2 standard	CDC-9	2 hp	1860 lbs
ERGO 6060 SRC-9	125021	2 standard	DCM-200A	2 hp	1836 lbs
ERGO 6060 SRC-9, CDC	125052	2 standard	CDC-9	2 hp	1956 lbs

# Pro-Finish® Cabinet Models

## FaStrip® Cabinets

MODEL DESCRIPTION	PART NUMBER	NUMBER OF DOORS	DUST COLLECTION	BLOWER MOTOR	SHIPPING WEIGHT
FaStrip® 2636 PRC-6	102130	1 standard	DCM-200	1½ hp	1380 lbs
FaStrip® 2636 PRC-6, CDC	102159	1 standard	CDC-6	1½ hp	1495 lbs
FaStrip® 2636 PR-6	140959	1 standard	—	—	660 lbs
ERGO FaStrip® 3648 PRC-6	121921	2 standard	DCM-200	1½ hp	1600 lbs
ERGO FaStrip® 3648 PRC-6, CDC	121951	2 standard	CDC-6	1½ hp	1900 lbs
FaStrip® 3648 PR-6	140950	2 standard	—	—	775 lbs
FaStrip® 3648 PRC-6	103129	2 standard	DCM-200	1½ hp	1500 lbs
FaStrip® 3648 PRC-6, CDC	103159	2 standard	CDC-6	1½ hp	1800 lbs
ERGO FaStrip® 3660 PRC-9	123921	2 standard	DCM-200A	2 hp	2075 lbs
ERGO FaStrip® 3660 PRC-9, CDC	123951	2 standard	CDC-9	2 hp	2195 lbs
FaStrip® 3660 PR-9	126951	2 standard	—	—	1245 lbs
FaStrip® 3660 PRC-9	126129	2 standard	DCM-200A	2 hp	1975 lbs
FaStrip® 3660 PRC-9, CDC	126159	2 standard	CDC-9	2 hp	2095 lbs
FaStrip® 3674 PRC-9	128129	2 standard	DCM-200A	2 hp	1970 lbs
FaStrip® 3674 PRC-9, CDC	128159	2 standard	CDC-9	2 hp	2290 lbs
ERGO FaStrip® 4848 PRC-9	122921	2 standard	DCM-200A	2 hp	1800 lbs
ERGO FaStrip® 4848 PRC-9, CDC	122951	2 standard	CDC-9	2 hp	2050 lbs
FaStrip® 4848 PR-9	140951	2 standard	—	—	965 lbs
FaStrip® 4848 PRC-9	104129	2 standard	DCM-200	1½ hp	1696 lbs
FaStrip® 4848 PRC-9, CDC	104159	2 standard	CDC-9	1½ hp	1816 lbs
ERGO FaStrip® 6060 PRC-9	125921	2 standard	DCM-200A	2 hp	2074 lbs
ERGO FaStrip® 6060 PRC-9, CDC	125951	2 standard	CDC-9	2 hp	2193 lbs
FaStrip® 6060 PR-9	140952	2 standard	—	—	1249 lbs
FaStrip® 6060 PRC-9	105129	2 standard	DCM-200A	2 hp	1975 lbs
FaStrip® 6060 PRC-9, CDC	105159	2 standard	CDC-9	2 hp	2094 lbs
FaStrip® 7272 PRC-9	127901	1 standard	DCM-200A	2 hp	3000 lbs
FaStrip® 7272 PRC-12	127923	1 standard	DCM-200B	5 hp	3100 lbs

## SafeStrip™ Fine Media Cabinets (Supplied with SafeStrip™ Pot)

MODEL DESCRIPTION	PART NUMBER	NUMBER OF DOORS	DUST COLLECTION	BLOWER MOTOR	SHIPPING WEIGHT
SafeStrip™ 2636	102032	1 standard	DCM-200	1½ hp	1870 lbs
SafeStrip™ 2636 CDC	102033	1 standard	CDC-6	1½ hp	1990 lbs
SafeStrip™ 3648	103032	2 standard	DCM-200	1½ hp	1985 lbs
SafeStrip™ 3648 CDC	103033	2 standard	CDC-6	1½ hp	2105 lbs
SafeStrip™ 4848	104032	2 standard	DCM-200	1½ hp	2070 lbs
SafeStrip™ 4848 CDC	104033	2 standard	CDC-6	1½ hp	2190 lbs
SafeStrip™ 6060	105032	2 standard	DCM-200A	2 hp	2425 lbs
SafeStrip™ 6060 CDC	105033	2 standard	CDC-9	2 hp	2545 lbs

## Single-Pass Cabinets (Supplied with Cabinet Pot)

MODEL DESCRIPTION	PART NUMBER	NUMBER OF DOORS	DUST COLLECTION	BLOWER MOTOR	SHIPPING WEIGHT
2636 PRC-6	102031	1 standard	DCM-200	1½ hp	1800 lbs
2636 PRC-6, CDC	102034	1 standard	CDC-6	1½ hp	1920 lbs
3648 PRC-6	103031	2 standard	DCM-200	1½ hp	1915 lbs
3648 PRC-6, CDC	103034	2 standard	CDC-6	1½ hp	2035 lbs
4848 PRC-6	104031	2 standard	DCM-200	1½ hp	1758 lbs
4848 PRC-6, CDC	104034	2 standard	CDC-6	1½ hp	1878 lbs
6060 PRC-9	105031	2 standard	DCM-200A	2 hp	2071 lbs
6060 PRC-9 CDC	105034	2 standard	CDC-9	2 hp	2191 lbs



# Dust Collector Models

## Dust Collectors

MODEL DESCRIPTION	PART NUMBER	COLLECTOR TYPE	FILTRATION AREA	BLOWER MOTOR	SHIPPING WEIGHT
DCM-80A	112000	Bag house	80 ft <sup>2</sup>	1 hp	300 lbs
DCR-80	112100	Bag house	80 ft <sup>2</sup>	—	250 lbs
DCM-200	113000	Bag house	200 ft <sup>2</sup>	1½ hp	730 lbs
DCM-200A	113001	Bag house	200 ft <sup>2</sup>	2 hp	730 lbs
DCM-200B	113002	Bag house	200 ft <sup>2</sup>	5 hp	850 lbs
CDC-6	113007	Cartridge	452 ft <sup>2</sup>	1½ hp	850 lbs
CDC-9	113011	Cartridge	452 ft <sup>2</sup>	2 hp	850 lbs
CDC-12	113013	Cartridge	452 ft <sup>2</sup>	5 hp	925 lbs
SEM-2	113033	Cartridge	206 ft <sup>2</sup>	1 hp	575 lbs





# Pro-Finish® Options

## 2636 Cabinets including Ergo-Blast & FaStrip® (400 and 600 CFM)

	FACTORY INSTALLED	CUSTOMER INSTALLED	SEE PAGE
<b>Three-Phase Electrical Options (400 CFM)</b>			
<b>Single Source:</b>			
208 Volt, 60 Hertz	139042	139117	A36
230 Volt, 60 Hertz	139043	139118	A36
460 Volt, 60 Hertz	139044	139119	A36
575 Volt, 60 Hertz	139045	139120	A36
380 Volt, 50 Hertz	139046	139121	A36
<b>Three-Phase Electrical Options (600 CFM)</b>			
<b>Single Source:</b>			
208 Volt, 60 Hertz	139047	139122	A36
230 Volt, 60 Hertz	139048	139123	A36
460 Volt, 60 Hertz	139049	139124	A36
575 Volt, 60 Hertz	139050	139125	A36
380 Volt, 50 Hertz	139051	139126	A36
<b>Cabinet Extended-Wear Options</b>			
Black curtain for cone *(Call about Ergo-Blast.)	510751	510831*	A59
Black curtains for front wall *(Call about Ergo-Blast.)	140642	140643*	A59
Black curtains for interior sides and back wall	510791	510871	A59
Conveying hose, heavy duty, 4" x 9'	140338	140354	A67
White curtain for cone *(Call about Ergo-Blast.)	140550	140558*	A59
White curtains for front wall *(Call about Ergo-Blast.)	140767	140969*	A59
White curtains for interior sides and back wall	140554	140562	A59
Window protector, plastic	509191	509191	A64
Window protector, screen	509201	509201	A64
<b>Reclaimer Extended-Wear Options (400 CFM)</b>			
Wear plate	514471	514501	A67
<b>Reclaimer Extended-Wear Options (600 CFM)</b>			
Ultrawear lining	526183	N/A	A67
Urethane spray lining	525861	N/A	A67
Wear plate	514481	514511	A67
<b>Cabinet Options</b>			
2'n'1 door basket, coated	140404	140405	A58
2'n'1 door basket, standard (uncoated)	140342	140406	A58
Antistatic strap	510411	510411	A58
Armrest assembly (included with Ergo-Blast)	140595	140595	A58
Door locking clamp, right side without timer	140624	140626	A58
Door locking clamp, right side with timer	140628	140630	A58
Glove hole plugs	140623	140622	A58
HEPA filter, cabinet inlet	Call factory	Call factory	A58
Left-side door	140345	140603	—
Magnetic separator (included with FaStrip®)	511572	511572	A58
Oscillator assembly (specify horizontal or vertical)	140424	140402	A59
Safety matting (specify length)	509002	509002	A60

*continued on next page*



## Options: Pro-Finish® Systems

### 2636 Cabinets including Ergo-Blast & FaStrip®—continued

	FACTORY INSTALLED	CUSTOMER INSTALLED	SEE PAGE
Sound attenuator (included with Ergo-Blast)	140597	140597	—
System security key-lock	140864	140864	A60
Timer package, electronic	140536	140535	A60
Timer package, mechanical	140420	140421	A60
Turntable, manual, 18" rolling, includes inside/outside tracks	140321	140321	A60
Turntable, manual, 18" stationary	140422	140422	A60
Turntable, manual, 18" stationary, low profile	140574	140574	A60
Turntable, manual, 24" stationary, low profile	140502	140502	A60
Vertical door	140491	140491	A63
Vibrating reclaim screen assembly (included with FaStrip®)	140335	140419	A64

### Pressure Cabinet Options

Blast hose, ½", top entry	140878	140879	A49
Blast hose, ¾", top entry, with ¼" Di-Carb™ nozzle	140635	140634	A68
Boron restrictor for MG-78 valve	290184	290184	A50
Cone, 60 degree, for pressure vessel	505002	140060	A68
Constant pressure control assembly	140523	Call factory	A68
Door sill package (included with Ergo-Blast)	140725	761551	A69
Fine tuning package	140511	140512	A69
Fine tuning package with choke	140509	140510	A69
Media regulator, aerated	140374	140360	A70
Media sensor, low level	140381	Call factory	A70
MG-78 CR valve (included with FaStrip®)	290234	290232	A71
Nozzle, ¼" boron	502032	502032	A49
Nozzle, ¼" Di-Carb™	501282	501282	A49
Nozzle holder, fixed	140401	140401	A71
Nozzles, second nozzle upgrade	140605	140604	A72
Pressure vessel, 3.5 cubic-foot assembly	140609	140607	A74
Sight glasses for 1.5 cubic-foot pressure vessel (two required)	545471	545471	A72
Sight glasses for 3.5 cubic-foot pressure vessel (two required)	545493	545493	A72
Sure-Flo® valve, automatic (included with FaStrip®)	290188	290188	A73

### Suction Cabinet Options

Gun holder, fixed	140400	140400	A75
Gun package, four gun upgrade (adds three guns)	140349	140353	A75
Gun package, three gun upgrade (adds two guns)	140348	140352	A75
Gun package, two gun upgrade (adds one gun)	140347	140351	A75
KLEEN™ package	140356	140391	A75
Nozzle, ⅝" boron	502081	502081	A57
Nozzle, ⅝" Di-Carb™	501341	501341	A57

### Dust Collector Options for DCM-80A (400 CFM)

Bag shaker, automatic electric, 115 volts	140340	140390	A65
Bag shaker, automatic pneumatic	140685	140686	A65
HEPA filter	140215- DCM80A	140215- DCM80A	A65
HEPA filter, pressure differential gauge assembly	140221	140221	A65
Leg extension kit	140170	140170	A65
Lid assembly for 55 gallon drum	140255	140255	A65
Manometer	140344	140398	A65
Sound attenuator/damper	140361	140361	A65





# Options: Pro-Finish® Systems

## 2636 Cabinets including Ergo-Blast & FaStrip®—continued

	FACTORY INSTALLED	CUSTOMER INSTALLED	SEE PAGE
<b>Dust Collector Options for SEM-2 (400 CFM)</b>			
Photohelic cartridge cleaning, automatic pulse	140810	140810	A66
Sound attenuator/damper	140759	140759	A66
<b>Dust Collector Options for DCM-200 (600 CFM)</b>			
Bag shaker, automatic electric, 115 volts	140340	140390	A65
Bag shaker, automatic pneumatic	140683	140684	A65
HEPA filter	140215	140215	A65
HEPA filter, pressure differential gauge assembly	140221	140221	A65
Leg extension kit	140180	140180	A65
Lid assembly for 55 gallon drum	140255	140255	A65
Manometer	140344	140398	A65
Sound attenuator/damper	140361	140361	A65
<b>Dust Collector Options for CDC-6 (600 CFM)</b>			
HEPA filter	140215	140215	A66
HEPA filter, pressure differential gauge assembly	140221	140221	A66
Photohelic cartridge cleaning, automatic pulse	140900	140900	A66
Leg extension kit	140185	140185	A66
Lid assembly for 55 gallon drum	140155	140155	A66
Sound attenuator/damper	140361	140361	A66
<b>Higher Volume Ventilation Options</b>			
900 CFM equipment	Call factory	Call factory	—
1200 CFM equipment	Call factory	Call factory	—





## Options: Pro-Finish® Systems

### 2636 SafeStrip™ and Single-Pass Models (600 CFM)

	FACTORY INSTALLED	CUSTOMER INSTALLED	SEE PAGE
<b>Three-Phase Electrical Options (600 CFM)</b>			
<b>Single Source:</b>			
208 Volt, 60 Hertz	139047	139122	A36
230 Volt, 60 Hertz	139048	139123	A36
460 Volt, 60 Hertz	139049	139124	A36
575 Volt, 60 Hertz	139050	139125	A36
380 Volt, 50 Hertz	139051	139126	A36
<b>Cabinet Extended-Wear Options</b>			
Black curtain for cone	510751	510831	A59
Black curtains for front wall	140642	140643	A59
Black curtains for interior sides and back wall	510791	510871	A59
Conveying hose, heavy duty, 6" x 9'	140338	140354	A67
White curtain for cone	140550	140558	A59
White curtains for front wall	140767	140969	A59
White curtains for interior sides and back wall	140554	140562	A59
Window protector, plastic	509191	509191	A64
Window protector, screen	509201	509201	A64
<b>Cabinet Options</b>			
2'n'1 door basket, coated	140404	140405	A58
2'n'1 door basket, standard (uncoated)	140342	140406	A58
Antistatic strap	510411	510411	A58
Armrest assembly	140595	140595	A58
Blast hose, 1/2", top entry	140878	140879	A49
Blast hose, 3/4", top entry, with 1/4" Di-Carb™ nozzle	140635	140634	A66
Boron restrictor for MG-78 valve (not available with SafeStrip™)	290184	290184	A50
Cone, 60 degree, for pressure vessel (not available with SafeStrip™)	505002	140060	A68
Door locking clamp, right side with timer	140628	140630	A58
Door locking clamp, right side without timer	140624	140626	A58
Door sill package	140725	761551	A69
Glove hole plugs	140623	140622	A58
HEPA filter, cabinet inlet	140190	140190	A58
Media sensor, low level (not available with SafeStrip™)	140361	140361	A70
Left-side door	140345	140603	—
Nozzle, 3/16" boron	502032	502032	A49
Nozzle, 3/16" Di-Carb™	501282	501282	A49
Nozzle holder, fixed	140401	140401	A71
Oscillator assembly (specify horizontal or vertical)	140424	140402	A59
Safety matting (specify length)	509002	509002	A60
Sight glasses for pressure vessel (two required) (not available with SafeStrip™)	545471	545471	A72
Sound attenuator	140597	140597	—
System security key-lock	140864	140864	A60
Timer package, electric	140536	140535	A60
Timer package, mechanical	140420	140421	A60
Turntable, manual, 18" rolling, includes inside/outside tracks	140321	140321	A60
Turntable, manual, 18" stationary	140422	140422	A60
Turntable, manual, 18" stationary, low profile	140574	140574	A60
Turntable, manual, 24" stationary, low profile	140502	140502	A60
Vertical door	140491	140491	A63

continued on next page



# Options: Pro-Finish® Systems

## 2636 SafeStrip™ and Single-Pass Models—continued

	FACTORY INSTALLED	CUSTOMER INSTALLED	SEE PAGE
<b>Dust Collector Options for DCM-200 (600 CFM)</b>			
Bag shaker, automatic electric, 115 volts	140340	140390	A65
Bag shaker, automatic pneumatic	140683	140684	A65
HEPA filter	140215	140215	A65
HEPA filter, pressure differential gauge assembly	140221	140221	A65
Leg extension kit	140180	140180	A65
Lid assembly for 55 gallon drum	140255	140255	A65
Manometer	140344	140398	A65
Sound attenuator/damper	140361	140361	A65
<b>Dust Collector Options for CDC-6 (600 CFM)</b>			
HEPA filter	140215	140215	A66
HEPA filter, pressure differential gauge assembly	140221	140221	A66
Photohelic cartridge cleaning, automatic pulse	140900	140900	A66
Leg extension kit	140185	140185	A66
Lid assembly for 55 gallon drum	140155	140155	A66
Sound attenuator/damper	140361	140361	A66
<b>Higher Volume Ventilation Options</b>			
900 CFM equipment	Call factory	Call factory	—
1200 CFM equipment	Call factory	Call factory	—





## Options: Pro-Finish® Systems

### 3648 Cabinets including Ergo-Blast and FaStrip® (400 and 600 CFM)

	FACTORY INSTALLED	CUSTOMER INSTALLED	SEE PAGE
<b>Three-Phase Electrical Options (400 CFM)</b>			
<b>Single Source:</b>			
208 Volt, 60 Hertz	139042	139117	A36
230 Volt, 60 Hertz	139043	139118	A36
460 Volt, 60 Hertz	139044	139119	A36
575 Volt, 60 Hertz	139045	139120	A36
380 Volt, 50 Hertz	139046	139121	A36
<b>Three-Phase Electrical Options (600 CFM)</b>			
<b>Single Source:</b>			
208 Volt, 60 Hertz	139047	139122	A36
230 Volt, 60 Hertz	139048	139123	A36
460 Volt, 60 Hertz	139049	139124	A36
575 Volt, 60 Hertz	139050	139125	A36
380 Volt, 50 Hertz	139051	139126	A36
<b>Cabinet Extended-Wear Options</b>			
Black curtain for cone *(Call about Ergo-Blast.)	510761	510841*	A59
Black curtains for front wall *(Call about Ergo-Blast.)	140640	140641*	A59
Black curtains for interior sides and back wall	510801	510881	A59
Conveying hose, heavy duty, 4" x 9'	140338	140354	A67
White curtain for cone *(Call about Ergo-Blast.)	140551	140559*	A59
White curtains for front wall *(Call about Ergo-Blast.)	140577	140973*	A59
White curtains for interior sides and back wall	140555	140563	A59
Window protector, plastic	509191	509191	A64
Window protector, screen	509201	509201	A64
<b>Reclaimer Extended-Wear Options (400 CFM)</b>			
Wear plate	514471	514501	A67
<b>Reclaimer Extended-Wear Options (600 CFM)</b>			
Ultrawear lining	526183	N/A	A67
Urethane spray lining	525861	N/A	A67
Wear plate	514481	514511	A67
<b>Cabinet Options</b>			
2'n'1 door basket, coated	140404	140405	A58
2'n'1 door basket, standard (uncoated)	140342	140406	A58
Antistatic strap	510411	510411	A58
Armrest assembly (included with Ergo-Blast)	140596	140596	A58
Door locking clamp, right side with timer	140628	140630	A58
Door locking clamp, right side without timer	140624	140626	A58
Door locking clamp, two doors with timer	140629	140631	A58
Door locking clamp, two doors without timer	140625	140627	A58
Glove hole plugs	140623	140622	A58
HEPA filter, cabinet inlet	140190	140190	A58
Magnetic separator (included with FaStrip®)	511572	511572	A58
Oscillator assembly (specify horizontal or vertical)	140424	140402	A59
Safety matting (specify length)	509002	509002	A60
Sound attenuator (included with Ergo-Blast)	140597	140597	A60
System security key-lock	140864	140864	A60

*continued on next page*



## Options: Pro-Finish® Systems

### 3648 Cabinets including Ergo-Blast and FaStrip®—continued

	FACTORY INSTALLED	CUSTOMER INSTALLED	SEE PAGE
Timer package, electric	140536	140535	A60
Timer package, mechanical	140420	140421	A60
Turntable, manual, 18" stationary	140422	140422	A60
Turntable, manual, 18" stationary, low profile	140574	140574	A60
Turntable, manual, 24" rolling, includes inside/outside tracks	140322	140322	A60
Turntable, manual, 24" stationary, low profile	140502	140502	A60
Turntable, powered, 24" rolling, includes inside/outside tracks ( <b>Consult factory!</b> )	140364	140364	A60
Turntable, powered, 24" stationary, low profile (not available with Ergo-Blast)	140504	140504	A60
Vertical door	140490	140490	A63
Vibrating reclaim screen assembly (included with FaStrip®)	140335	140419	A64

### Pressure Cabinet Options

Blast hose, ½", top entry	140878	140879	A48
Blast hose, ¾", top entry, with ¼" Di-Carb™ nozzle	140635	140634	A68
Boron restrictor for MG-78 valve	290184	290184	A50
Cone, 60 degree, for pressure vessel	505002	140060	A68
Constant pressure control assembly	140523	Call Factory	A68
Door sill package for one door (two included with Ergo-Blast)	140726	761561	A69
Fine tuning package	140511	140512	A69
Fine tuning package with choke	140509	140510	A69
Media regulator, aerated	140374	140360	A70
Media sensor, low level	140381	Call Factory	A70
MG-78 CR valve (included with FaStrip®)	290234	290232	A71
Nozzle, ¼" boron	502032	502032	A49
Nozzle, ¼" Di-Carb™	501282	501282	A49
Nozzle holder, fixed	140401	140401	A71
Nozzles, second nozzle upgrade	140605	140604	A72
Pressure vessel, 3.5 cubic-foot assembly	140609	140607	A74
Sight glasses for 1.5 cubic-foot pressure vessel (two required)	545471	545471	A72
Sight glasses for 3.5 cubic-foot pressure vessel (two required)	545493	545493	A72
Sure-Flo® valve, automatic (included with FaStrip®)	290188	290188	A73

### Suction Cabinet Options

Gun holder, fixed	140400	140400	A75
Gun package, four gun upgrade (adds three guns)	140349	140353	A75
Gun package, three gun upgrade (adds two guns)	140348	140352	A75
Gun package, two gun upgrade (adds one gun)	140347	140351	A75
KLEEN™ package	140357	140392	A75
Nozzle, ⅝" boron	502081	502081	A57
Nozzle, ⅝" Di-Carb™	501341	501341	A57

### Dust Collector Options for DCM-80A (400 CFM)

Bag shaker, automatic electric, 115 volts	140340	140390	A65
Bag shaker, automatic pneumatic	140685	140686	A65
HEPA filter	140215- DCM80A	140215- DCM80A	A65
HEPA filter, pressure differential gauge assembly	140221	140221	A65
Leg extension kit	140170	140170	A65
Lid assembly for 55 gallon drum	140255	140255	A65
Manometer	140344	140398	A65
Sound attenuator/damper	140361	140361	A65

*continued on next page*



# Options: Pro-Finish® Systems

## 3648 Cabinets including Ergo-Blast and FaStrip®—continued

	FACTORY INSTALLED	CUSTOMER INSTALLED	SEE PAGE
<b>Dust Collector Options for SEM-2 (400 CFM)</b>			
Photohelic cartridge cleaning, automatic pulse	140810	140810	A66
Sound attenuator/damper	140759	140759	A66
<b>Dust Collector Options for DCM-200 (600 CFM)</b>			
Bag shaker, automatic electric, 115 volts	140340	140390	A65
Bag shaker, automatic pneumatic	140683	140684	A65
HEPA filter	140215	140215	A65
HEPA filter, pressure differential gauge assembly	140221	140221	A65
Leg extension kit	140180	140180	A65
Lid assembly for 55 gallon drum	140255	140255	A65
Manometer	140344	140398	A65
Sound attenuator/damper	140361	140361	A65
<b>Dust Collector Options for CDC-6 (600 CFM)</b>			
HEPA filter	140215	140215	A66
HEPA filter, pressure differential gauge assembly	140221	140221	A66
Photohelic cartridge cleaning, automatic pulse	140900	140900	A66
Leg extension kit	140185	140185	A66
Lid assembly for 55 gallon drum	140155	140155	A66
Sound attenuator/damper	140361	140361	—
<b>Higher Volume Ventilation Options</b>			
900 CFM equipment	Call Factory	Call Factory	—
1200 CFM equipment	Call Factory	Call Factory	—

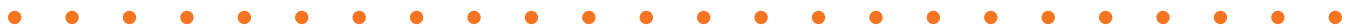



## Options: Pro-Finish® Systems

### 3648 SafeStrip™ and Single-Pass Models (600 CFM)

	FACTORY INSTALLED	CUSTOMER INSTALLED	SEE PAGE
<b>Three-Phase Electrical Options (600 CFM)</b>			
<b>Single Source:</b>			
208 Volt, 60 Hertz	139047	139122	A36
230 Volt, 60 Hertz	139048	139123	A36
460 Volt, 60 Hertz	139049	139124	A36
575 Volt, 60 Hertz	139050	139125	A36
380 Volt, 50 Hertz	139051	139126	A36
<b>Cabinet Extended-Wear Options</b>			
Black curtain for cone	510801	510841	A59
Black curtains for front wall	140640	140641	A59
Black curtains for interior sides and back wall	510791	510871	A59
Conveying hose, heavy duty, 6" x 9'	140338	140354	A67
White curtain for cone	140551	140559	A59
White curtains for front wall	140577	140973	A59
White curtains for interior sides and back wall	140555	140563	A59
Window protector, plastic	509191	509191	A64
Window protector, screen	509201	509201	A64
<b>Cabinet Options</b>			
2'n'1 door basket, coated	140404	140405	A58
2'n'1 door basket, standard (uncoated)	140342	140406	A58
Antistatic strap	510411	510411	A58
Armrest assembly	140596	140596	A58
Blast hose, 1/2", top entry	140878	140879	A49
Blast hose, 3/4", top entry, with 1/4" Di-Carb™ nozzle	140635	140634	A66
Boron restrictor for MG-78 valve (not available with SafeStrip™)	290184	290184	A50
Cone, 60 degree, for pressure vessel (not available with SafeStrip™)	505002	140060	A68
Door locking clamp, right side with timer	140628	140630	A58
Door locking clamp, right side without timer	140624	140626	A58
Door locking clamp, two doors with timer	140629	140631	A58
Door locking clamp, two doors without timer	140625	140627	A58
Door sill package for one door	140726	761561	A69
Glove hole plugs	140623	140622	A58
Media sensor, low level (not available with SafeStrip™)	140361	140361	A70
HEPA filter, cabinet inlet	140190	140190	A58
Nozzle, 3/16" boron	502032	502032	A49
Nozzle, 3/16" Di-Carb™	501282	501282	A49
Nozzle holder, fixed	140401	140401	A71
Oscillator assembly (specify horizontal or vertical)	140424	140402	A59
Safety matting (specify length)	509002	509002	A60
Sight glasses for 1.5 cubic-foot pressure vessel (two required)	545471	545471	A72
Sight glasses for 3.5 cubic-foot pressure vessel (two required)	545493	545493	A72
Sound attenuator	140597	140597	—
System security key-lock	140864	140864	A60
Timer package, electric	140536	140535	A60
Timer package, mechanical	140420	140421	A60
Turntable, manual, 18" stationary	140422	140422	A60
Turntable, manual, 18" stationary, low profile	140574	140574	A60
Turntable, manual, 24" rolling, includes inside/outside tracks	140322	140322	A60

*continued on next page*



# Options: Pro-Finish® Systems

## 3648 SafeStrip™ and Single-Pass Models—continued

	FACTORY INSTALLED	CUSTOMER INSTALLED	SEE PAGE
Turntable, manual, 24" stationary, low profile	140502	140502	A60
Turntable, powered, 24" rolling, includes inside/outside tracks <b>(Consult factory!)</b>	140364	140364	A60
Turntable, powered, 24" stationary, low profile	140504	140504	A60
Vertical door	140490	140490	A63

### Dust Collector Options for DCM-200 (600 CFM)

Bag shaker, automatic electric, 115 volts	140340	140390	A65
Bag shaker, automatic pneumatic	140683	140684	A65
HEPA filter	140215	140215	A65
HEPA filter, pressure differential gauge assembly	140221	140221	A65
Leg extension kit	140180	140180	A65
Lid assembly for 55 gallon drum	140255	140255	A65
Manometer	140344	140398	A65
Sound attenuator/damper	140361	140361	A65

### Dust Collector Options for CDC-6 (600 CFM)

HEPA filter	140215	140215	A66
HEPA filter, pressure differential gauge assembly	140221	140221	A66
Photohelic cartridge cleaning, automatic pulse	140900	140900	A66
Leg extension kit	140185	140185	A66
Lid assembly for 55 gallon drum	140155	140155	A66
Sound attenuator/damper	140361	140361	A66

### Higher Volume Ventilation Options

900 CFM equipment	Call factory	Call factory	—
1200 CFM equipment	Call factory	Call factory	—







## Options: Pro-Finish® Systems

### 3660 Cabinets including Ergo-Blast and FaStrip® (600 and 900 CFM)

	FACTORY INSTALLED	CUSTOMER INSTALLED	SEE PAGE
<b>Three-Phase Electrical Options (600 CFM)</b>			
<b>Single Source:</b>			
208 Volt, 60 Hertz	139047	139122	A36
230 Volt, 60 Hertz	139048	139123	A36
460 Volt, 60 Hertz	139049	139124	A36
575 Volt, 60 Hertz	139050	139125	A36
380 Volt, 50 Hertz	139051	139126	A36
<b>Three-Phase Electrical Options (900 CFM)</b>			
<b>Single Source:</b>			
208 Volt, 60 Hertz	139052	139127	A36
230 Volt, 60 Hertz	139053	139128	A36
460 Volt, 60 Hertz	139054	139129	A36
575 Volt, 60 Hertz	139055	139130	A36
380 Volt, 50 Hertz	139056	139131	A36
<b>Cabinet Extended-Wear Options</b>			
Black curtain for cone *(Call about Ergo-Blast.)	140826	140832*	A59
Black curtains for front wall *(Call about Ergo-Blast.)	140827	140833*	A59
Black curtains for interior sides and back wall	140828	140834	A59
Conveying hose, heavy duty, 4" x 9', 600 CFM	140338	140354	A67
Conveying hose, heavy duty, 6" x 12', 900 CFM	140339	140355	A67
White curtain for cone *(Call about Ergo-Blast.)	140829	140835*	A59
White curtains for front wall *(Call about Ergo-Blast.)	140830	140836*	A59
White curtains for interior sides and back wall	140831	140837	A59
Window protector, plastic	509191	509191	A64
Window protector, screen	509201	509201	A64
<b>Reclaimer Extended-Wear Options (600 CFM)</b>			
Ultrawear lining	526183	N/A	A67
Urethane spray lining	525861	N/A	A67
Wear plate	514481	514511	A67
<b>Reclaimer Extended-Wear Options (900 CFM)</b>			
Ultrawear lining	526193	N/A	A67
Urethane spray lining	525891	N/A	A67
Wear plate	514491	514521	A67
<b>Cabinet Options</b>			
2'n'1 door basket, coated	140404	140405	A58
2'n'1 door basket, standard (uncoated)	140342	140406	A58
Antistatic strap	510411	510411	A58
Armrest assembly (included with Ergo-Blast)	140596	140596	A58
Door locking clamp, right side with timer	140628	140630	A58
Door locking clamp, right side without timer	140624	140626	A58
Door locking clamp, two doors with timer	140629	140631	A58
Door locking clamp, two doors without timer	140625	140627	A58
Glove hole plugs	140623	140622	A58
HEPA filter, cabinet inlet	140190	140190	A58
Magnetic separator (included with FaStrip®)	511572	511572	A58
Oscillator assembly (specify horizontal or vertical)	140424	140402	A59

*continued on next page*



## Options: Pro-Finish® Systems

### 3660 Cabinets including Ergo-Blast and FaStrip®—continued

	FACTORY INSTALLED	CUSTOMER INSTALLED	SEE PAGE
Safety matting (specify length)	509002	509002	A60
Sound attenuator (included with Ergo-Blast)	140597	140597	—
System security key-lock	140864	140864	A60
Timer package, electric	140536	140535	A60
Timer package, mechanical	140420	140421	A60
Turntable, manual, 18" stationary	140422	140422	A60
Turntable, manual, 18" stationary, low profile	140574	140574	A60
Turntable, manual, 24" rolling, includes inside/outside tracks	140324	140324	A60
Turntable, manual, 24" stationary, low profile	140502	140502	A60
Turntable, powered, 24" rolling, includes inside/outside tracks ( <b>Consult factory!</b> )	140375	140375	A60
Turntable, powered, 24" stationary, low profile (not available with Ergo-Blast)	140504	140504	A60
Vertical door	140490	140490	A63
Vibrating reclaiming screen assembly (included with FaStrip®)	140335	140419	A64

### Pressure Cabinet Options

Blast hose, ½", top entry	140878	140879	A49
Blast hose, ¾", top entry, with ¼" Di-Carb™ nozzle	140635	140634	A68
Boron restrictor for MG-78 valve	290184	290184	A50
Cone, 60 degree, for pressure vessel	505002	140060	A68
Constant pressure control assembly	140523	Call Factory	A68
Door sill package for one door (two included with Ergo-Blast)	140726	761561	A69
Fine tuning package	140511	140512	A69
Fine tuning package with choke	140509	140510	A69
Media regulator, aerated	140374	140360	A70
Media sensor, low level	140381	Call Factory	A70
MG-78 CR valve (included with FaStrip®)	290234	290232	A71
Nozzle, ¼" boron	502032	502032	A49
Nozzle, ¼" Di-Carb™	501282	501282	A49
Nozzle holder, fixed	140401	140401	A71
Nozzles, second nozzle upgrade	140605	140604	A72
Pressure vessel, 3.5 cubic-foot assembly, 600 CFM	140609	140607	A74
Pressure vessel, 3.5 cubic-foot assembly, 900 CFM	140610	140608	A74
Sight glasses for 1.5 cubic-foot pressure vessel (two required)	545471	545471	A72
Sight glasses for 3.5 cubic-foot pressure vessel (two required)	545493	545493	A72
Sure-Flo® valve, automatic (included with FaStrip®)	290188	290188	A73

### Suction Cabinet Options

Gun holder, fixed	140400	140400	A75
Gun package, four gun upgrade (adds three guns)	140349	140353	A75
Gun package, three gun upgrade (adds two guns)	140348	140352	A75
Gun package, two gun upgrade (adds one gun)	140347	140351	A75
KLEEN™ package	140357	140392	A75
Nozzle, ¼" boron	502081	502081	A57
Nozzle, ¼" Di-Carb™	501341	501341	A57

continued on next page



# Options: Pro-Finish® Systems

## 3660 Cabinets including Ergo-Blast and FaStrip®—continued

	FACTORY INSTALLED	CUSTOMER INSTALLED	SEE PAGE
<b>Dust Collector Options for DCM-200 (600 CFM)</b>			
Bag shaker, automatic electric, 115 volts	140340	140390	A65
Bag shaker, automatic pneumatic	140683	140684	A65
HEPA filter	140215	140215	A65
HEPA filter, pressure differential gauge assembly	140221	140221	A65
Leg extension kit	140180	140180	A65
Lid assembly for 55 gallon drum	140255	140255	A65
Manometer	140344	140398	A65
Sound attenuator/damper	140361	140361	A65
<b>Dust Collector Options for CDC-6 (600 CFM)</b>			
HEPA filter	140215	140215	A66
HEPA filter, pressure differential gauge assembly	140221	140221	A66
Photohelic cartridge cleaning, automatic pulse	140900	140900	A66
Leg extension kit	140185	140185	A66
Lid assembly for 55 gallon drum	140155	140155	A66
Sound attenuator/damper	140361	140361	A66
<b>Dust Collector Options for DCM-200A (900 CFM)</b>			
Bag shaker, automatic electric, 115 volts	140340	140390	A65
Bag shaker, automatic pneumatic	140683	140684	A65
HEPA filter	140215	140215	A65
HEPA filter, pressure differential gauge assembly	140221	140221	A65
Leg extension kit	140180	140180	A65
Lid assembly for 55 gallon drum	140255	140255	A65
Manometer	140344	140398	A65
Sound attenuator/damper	140769	140769	A65
<b>Dust Collector Options for CDC-9 (900 CFM)</b>			
HEPA filter	140215	140215	A66
HEPA filter, pressure differential gauge assembly	140221	140221	A66
Photohelic cartridge cleaning, automatic pulse	140900	140900	A66
Leg extension kit	140185	140185	A66
Lid assembly for 55 gallon drum	140155	140155	A66
Sound attenuator/damper	140769	140769	A66
<b>Higher Volume Ventilation Options</b>			
1200 CFM equipment	Call factory	Call factory	—





## 3674 Cabinets including FaStrip® (900 CFM)

	FACTORY INSTALLED	CUSTOMER INSTALLED	SEE PAGE
--	----------------------	-----------------------	-------------

### Three-Phase Electrical Options (900 CFM)

#### Single Source:

208 Volt, 60 Hertz	139052	139127	A36
230 Volt, 60 Hertz	139053	139128	A36
460 Volt, 60 Hertz	139054	139129	A36
575 Volt, 60 Hertz	139055	139130	A36
380 Volt, 50 Hertz	139056	139131	A36

### Cabinet Extended-Wear Options

Black curtain for cone	140693	510853	A59
Black curtains for front wall	140694	510854	A59
Black curtains for interior sides and back wall	140692	510855	A59
Conveying hose, heavy duty, 6" x 12'	140339	140355	A67
White curtain for cone	140886	140855	A59
White curtains for front wall	140967	140968	A59
White curtains for interior sides and back wall	140888	140887	A59
Window protector, plastic	509191	509191	A64
Window protector, screen	509201	509201	A64

### Reclaimer Extended-Wear Options (900 CFM)

Ultrawear lining	526193	N/A	A67
Urethane spray lining	525891	N/A	A67
Wear plate	514491	514521	A67

### Cabinet Options

2'n'1 door basket, coated	140404	140405	A58
2'n'1 door basket, standard (uncoated)	140342	140406	A58
Antistatic strap	510411	510411	A58
Armrest assembly	140596	140596	A58
Door locking clamp, right side with timer	140628	140630	A58
Door locking clamp, right side without timer	140624	140626	A58
Door locking clamp, two doors with timer	140629	140631	A58
Door locking clamp, two doors without timer	140625	140627	A58
Glove hole plugs	140623	140622	A58
HEPA filter, cabinet inlet	140190	140190	A58
Magnetic separator (included with FaStrip®)	511572	511572	A58
Oscillator assembly (specify horizontal or vertical)	140424	140402	A59
Safety matting (specify length)	509002	509002	A60
Sound attenuator	140597	140597	—
System security key-lock	140864	140864	A60
Timer package, electric	140536	140535	A60
Timer package, mechanical	140420	140421	A60
Turntable, manual, 18" stationary	140422	140422	A60
Turntable, manual, 18" stationary, low profile	140574	140574	A60
Turntable, manual, 24" rolling, includes inside/outside tracks	140322	140322	A60
Turntable, manual, 24" stationary, low profile	140502	140502	A60
Turntable, powered, 24" rolling, includes inside/outside tracks ( <b>Consult factory!</b> )	140364	140364	A60
Turntable, powered, 24" stationary, low profile	140504	140504	A60
Vertical door	140490	140490	A63
Vibrating reclaimer screen assembly (included with FaStrip®)	140335	140419	A64

continued on next page



# Options: Pro-Finish® Systems

## 3674 Cabinets including FaStrip®—continued

	FACTORY INSTALLED	CUSTOMER INSTALLED	SEE PAGE
<b>Pressure Cabinet Options</b>			
Blast hose, ½", top entry	140878	140879	A49
Blast hose, ¾", top entry, with ¼" Di-Carb™ nozzle	140635	140634	A68
Boron restrictor for MG-78 valve	290184	290184	A50
Cone, 60 degree, for pressure vessel	505002	140060	A68
Constant pressure control assembly	140523	Call Factory	A68
Door sill package for one door	140726	761561	A69
Fine tuning package	140511	140512	A69
Fine tuning package with choke	140509	140510	A69
Media regulator, aerated	140374	140360	A70
Media sensor, low level	140381	Call Factory	A70
MG-78 CR valve (included with FaStrip®)	290234	290232	A71
Nozzle, ⅜" boron	502032	502032	A49
Nozzle, ⅜" Di-Carb™	501282	501282	A49
Nozzle holder, fixed	140401	140401	A71
Nozzles, second nozzle upgrade	140605	140604	A72
Pressure vessel, 3.5 cubic-foot assembly	140610	140608	A74
Sight glasses for 1.5 cubic-foot pressure vessel (two required)	545471	545471	A72
Sight glasses for 3.5 cubic-foot pressure vessel (two required)	545493	545493	A72
Sure-Flo® valve, automatic (included with FaStrip®)	290188	290188	A73
<b>Suction Cabinet Options</b>			
Gun holder, fixed	140400	140400	A75
Gun package, four gun upgrade (adds three guns)	140349	140353	A75
Gun package, three gun upgrade (adds two guns)	140348	140352	A75
Gun package, two gun upgrade (adds one gun)	140347	140351	A75
KLEEN™ package	140357	140392	A75
Nozzle, ⅝" boron	502081	502081	A57
Nozzle, ⅝" Di-Carb™	501341	501341	A57
<b>Dust Collector Options for DCM-200A (900 CFM)</b>			
Bag shaker, automatic electric, 115 volts	140340	140390	A65
Bag shaker, automatic pneumatic	140683	140684	A65
HEPA filter	140215	140215	A65
HEPA filter, pressure differential gauge assembly	140221	140221	A65
Leg extension kit	140180	140180	A65
Lid assembly for 55 gallon drum	140255	140255	A65
Manometer	140344	140398	A65
Sound attenuator/damper	140769	140769	A65
<b>Dust Collector Options for CDC-9 (900 CFM)</b>			
HEPA filter	140215	140215	A66
HEPA filter, pressure differential gauge assembly	140221	140221	A66
Photohelic cartridge cleaning, automatic pulse	140900	140900	A66
Leg extension kit	140185	140185	A66
Lid assembly for 55 gallon drum	140155	140155	A66
Sound attenuator/damper	140769	140769	A66
<b>Higher Volume Ventilation Options</b>			
1200 CFM equipment	Call factory	Call factory	—





## Options: Pro-Finish® Systems

### 3696 Twin Cabinets including Ergo-Blast (400 and 600 CFM)

	FACTORY INSTALLED	CUSTOMER INSTALLED	SEE PAGE
--	----------------------	-----------------------	-------------

*Two items required for upgrades of both cabinets.*

#### Three-Phase Electrical Options (400 CFM)

**Single Source:**

208 Volt, 60 Hertz	139042	139117	A36
230 Volt, 60 Hertz	139043	139118	A36
460 Volt, 60 Hertz	139044	139119	A36
575 Volt, 60 Hertz	139045	139120	A36
380 Volt, 50 Hertz	139046	139121	A36

#### Three-Phase Electrical Options (600 CFM)

**Single Source:**

208 Volt, 60 Hertz	139047	139122	A36
230 Volt, 60 Hertz	139048	139123	A36
460 Volt, 60 Hertz	139049	139124	A36
575 Volt, 60 Hertz	139050	139125	A36
380 Volt, 50 Hertz	139051	139126	A36

#### Cabinet Extended-Wear Options

Black curtain for cone *(Call about Ergo-Blast.)	510761	510841*	A59
Black curtains for front wall *(Call about Ergo-Blast.)	140640	140641*	A59
Black curtains for interior sides and back wall	510801	510881	A59
Conveying hose, heavy duty, 4" x 9'	140338	140354	A67
White curtain for cone *(Call about Ergo-Blast.)	140551	140559*	A59
White curtains for front wall *(Call about Ergo-Blast.)	140577	140973*	A59
White curtains for interior sides and back wall	140555	140563	A59
Window protector, plastic	509191	509191	A64
Window protector, screen	509201	509201	A64

#### Reclaimer Extended-Wear Options (400 CFM)

Wear plate	514471	514501	A67
------------	--------	--------	-----

#### Reclaimer Extended-Wear Options (600 CFM)

Ultrawear lining	526183	N/A	A67
Urethane spray lining	525861	N/A	A67
Wear plate	514481	514511	A67

#### Cabinet Options

2'n'1 door basket, coated	140404	140405	A58
2'n'1 door basket, standard (uncoated)	140342	140406	A58
Antistatic strap	510411	510411	A58
Armrest assembly (included with Ergo-Blast)	140596	140596	A58
Door locking clamp, right side with timer	140628	140630	A58
Door locking clamp, right side without timer	140624	140626	A58
Door locking clamp, two doors with timer	140629	140631	A58
Door locking clamp, two doors without timer	140625	140627	A58
Glove hole plugs	140623	140622	A58
HEPA filter, cabinet inlet	140190	140190	A58
Magnetic separator (included with FaStrip®)	511572	511572	A58
Oscillator assembly (specify horizontal or vertical)	140424	140402	A59
Safety matting (specify length)	509002	509002	A60

*continued on next page*



## Options: Pro-Finish® Systems

### 3696 Twin Cabinets including Ergo-Blast—continued

	FACTORY INSTALLED	CUSTOMER INSTALLED	SEE PAGE
Sound attenuator (included with Ergo-Blast)	140597	140597	—
System security key-lock	140864	140864	A60
Timer package, electric	140536	140535	A60
Timer package, mechanical	140420	140421	A60
Turntable, manual, 18" stationary	140422	140422	A60
Turntable, manual, 18" stationary, low profile	140574	140574	A60
Turntable, manual, 24" rolling, includes inside/outside tracks (For single cabinet only.)	140322	140322	A60
Turntable, manual, 24" stationary, low profile	140502	140502	A60
Turntable, powered, 24" stationary, low profile <b>(Consult factory!)</b> (For single cabinet only. Not available with Ergo-Blast)	140504	140504	A60
Vertical door	140490	140490	A63
Vibrating reclaimers screen assembly (included with FaStrip®)	140335	140419	A64

### Pressure Cabinet Options

Blast hose, 1/2", top entry	140878	140879	A49
Blast hose, 3/4", top entry, with 1/4" Di-Carb™ nozzle	140635	140634	A68
Boron restrictor for MG-78 valve	290184	290184	A50
Cone, 60 degree, for pressure vessel	505002	140060	A68
Constant pressure control assembly	140523	Call Factory	A68
Door sill package for one door (two included with Ergo-Blast)	140726	761561	A69
Fine tuning package	140511	140512	A69
Fine tuning package with choke	140509	140510	A69
Media regulator, aerated	140374	140360	A70
Media sensor, low level	140381	Call Factory	A70
MG-78 CR valve (included with FaStrip®)	290234	290232	A71
Nozzle, 3/16" boron	502032	502032	A49
Nozzle, 3/16" Di-Carb™	501282	501282	A49
Nozzle holder, fixed	140401	140401	A71
Nozzles, second nozzle upgrade	140605	140604	A72
Pressure vessel, 3.5 cubic-foot assembly	140609	140607	A74
Sight glasses for 1.5 cubic-foot pressure vessel (two required)	545471	545471	A72
Sight glasses for 3.5 cubic-foot pressure vessel (two required)	545493	545493	A72
Sure-Flo® valve, automatic (included with FaStrip®)	290188	290188	A73

continued on next page



# Options: Pro-Finish® Systems

## 3696 Twin Cabinets including Ergo-Blast—continued

	FACTORY INSTALLED	CUSTOMER INSTALLED	SEE PAGE
<b>Suction Cabinet Options</b>			
Gun holder, fixed	140400	140400	A75
Gun package, four gun upgrade (adds three guns)	140349	140353	A75
Gun package, three gun upgrade (adds two guns)	140348	140352	A75
Gun package, two gun upgrade (adds one gun)	140347	140351	A75
KLEEN™ package	140357	140392	A75
Nozzle, 5/16" boron	502081	502081	A57
Nozzle, 5/16" Di-Carb™	501341	501341	A57
<b>Dust Collector Options for DCM-80A (400 CFM)</b>			
Bag shaker, automatic electric, 115 volts	140340	140390	A65
Bag shaker, automatic pneumatic	140685	140686	A65
HEPA filter	140215- DCM80A	140215- DCM80A	A65
HEPA filter, pressure differential gauge assembly	140221	140221	A65
Leg extension kit	140170	140170	A65
Lid assembly for 55 gallon drum	140255	140255	A65
Manometer	140344	140398	A65
Sound attenuator/damper	140361	140361	A65
<b>Dust Collector Options for SEM-2 (400 CFM)</b>			
Photohelic cartridge cleaning, automatic pulse	140810	140810	A66
Sound attenuator/damper	140759	140759	A66
<b>Dust Collector Options for DCM-200 (600 CFM)</b>			
Bag shaker, automatic electric, 115 volts	140340	140390	A65
Bag shaker, automatic pneumatic	140683	140684	A65
HEPA filter	140215	140215	A65
HEPA filter, pressure differential gauge assembly	140221	140221	A65
Leg extension kit	140180	140180	A65
Lid assembly for 55 gallon drum	140255	140255	A65
Manometer	140344	140398	A65
Sound attenuator/damper	140361	140361	A65
<b>Dust Collector Options for CDC-6 (600 CFM)</b>			
HEPA filter	140215	140215	A66
HEPA filter, pressure differential gauge assembly	140221	140221	A66
Leg extension kit	140185	140185	A66
Lid assembly for 55 gallon drum	140155	140155	A66
Sound attenuator/damper	140361	140361	A66
<b>Higher Volume Ventilation Options</b>			
900 CFM equipment	Call factory	Call factory	—
1200 CFM equipment	Call factory	Call factory	—







## Options: Pro-Finish® Systems

### 4848 Cabinets including Ergo-Blast and FaStrip® (600 and 900 CFM)

	FACTORY INSTALLED	CUSTOMER INSTALLED	SEE PAGE
<b>Three-Phase Electrical Options (600 CFM)</b>			
<b>Single Source:</b>			
208 Volt, 60 Hertz	139047	139122	A36
230 Volt, 60 Hertz	139048	139123	A36
460 Volt, 60 Hertz	139049	139124	A36
575 Volt, 60 Hertz	139050	139125	A36
380 Volt, 50 Hertz	139051	139126	A36
<b>Three-Phase Electrical Options (900 CFM)</b>			
<b>Single Source:</b>			
208 Volt, 60 Hertz	139052	139127	A36
230 Volt, 60 Hertz	139053	139128	A36
460 Volt, 60 Hertz	139054	139129	A36
575 Volt, 60 Hertz	139055	139130	A36
380 Volt, 50 Hertz	139056	139131	A36
<b>Cabinet Extended-Wear Options</b>			
Black curtain for cone *(Call about Ergo-Blast.)	510771	510851*	A59
Black curtains for front wall *(Call about Ergo-Blast.)	140640	140641*	A59
Black curtains for interior sides and back wall	510811	510891	A59
Conveying hose, heavy duty, 4" x 9', 600 CFM	140338	140354	A67
Conveying hose, heavy duty, 6" x 12', 900 CFM	140339	140355	A59
White curtain for cone *(Call about Ergo-Blast.)	140552	140560*	A59
White curtains for front wall *(Call about Ergo-Blast.)	140577	140973*	A59
White curtains for interior sides and back wall	140556	140564	A59
Window protector, plastic	509191	509191	A64
Window protector, screen	509201	509201	A64
<b>Reclaimer Extended-Wear Options (600 CFM)</b>			
Ultrawear lining	526183	N/A	A67
Urethane spray lining	525861	N/A	A67
Wear plate	514481	514511	A67
<b>Reclaimer Extended-Wear Options (900 CFM)</b>			
Ultrawear lining	526193	N/A	A67
Urethane spray lining	525891	N/A	A67
Wear plate	514491	514521	A67
<b>Cabinet Options</b>			
2'n'1 door basket, coated	140404	140405	A68
2'n'1 door basket, standard (uncoated)	140342	140406	A68
Antistatic strap	510411	510411	A68
Armrest assembly (included with Ergo-Blast)	140596	140596	A68
Door locking clamp, right side with timer	140628	140630	A68
Door locking clamp, right side without timer	140624	140626	A68
Door locking clamp, two doors with timer	140629	140631	A68
Door locking clamp, two doors without timer	140625	140627	A68
Glove hole plugs	140623	140622	A68
HEPA filter, cabinet inlet	140190	140190	A68
Magnetic separator (included with FaStrip®)	511572	511572	A68
Oscillator assembly (specify horizontal or vertical)	140424	140402	A69

*continued on next page*



## Options: Pro-Finish® Systems

### 4848 Cabinets including Ergo-Blast and FaStrip®—continued

	FACTORY INSTALLED	CUSTOMER INSTALLED	SEE PAGE
Safety matting (specify length)	509002	509002	A60
Sound attenuator (included with Ergo-Blast)	140597	140597	—
System security key-lock	140864	140864	A60
Timer package, electric	140536	140535	A60
Timer package, mechanical	140420	140421	A60
Turntable, manual, 18" stationary	140422	140422	A60
Turntable, manual, 18" stationary, low profile	140574	140574	A60
Turntable, manual, 24" rolling, includes inside/outside tracks	140322	140322	A60
Turntable, manual, 24" stationary, low profile	140502	140502	A60
Turntable, manual, 36" rolling, includes inside/outside tracks	140323	140323	A60
Turntable, manual, 36" stationary, low profile	140503	140503	A60
Turntable, powered, 24" rolling, includes inside/outside tracks <b>(Consult factory!)</b>	140364	140364	A60
Turntable, powered, 24" stationary, low profile (not available with Ergo-Blast)	140504	140504	A60
Turntable, powered, 36" rolling, includes inside/outside tracks <b>(Consult factory!)</b>	140365	140365	A60
Turntable, powered, 36" stationary, low profile (not available with Ergo-Blast)	140505	140505	A60
Vertical door	140489	140489	A63
Vibrating reclaimers screen assembly (included with FaStrip®)	140335	140419	A64

### Pressure Cabinet Options

Blast hose, ½", top entry	140878	140879	A49
Blast hose, ¾", top entry, with ¼" Di-Carb™ nozzle	140635	140634	A68
Boron restrictor for MG-78 valve	290184	290184	A50
Cone, 60 degree, for pressure vessel	505002	140060	A68
Constant pressure control assembly	140523	Call factory	A68
Door sill package for one door (two included with Ergo-Blast)	140727	761571	A69
Fine tuning package	140511	140512	A69
Fine tuning package with choke	140509	140510	A69
Media regulator, aerated	140374	140360	A70
Media sensor, low level	140381	Call factory	A70
MG-78 CR valve (included with FaStrip®)	290234	290232	A71
Nozzle, ⅜" boron	502032	502032	A49
Nozzle, ⅜" Di-Carb™	501282	501282	A49
Nozzle holder, fixed	140401	140401	A71
Nozzles, second nozzle upgrade	140605	140604	A72
Pressure vessel, 3.5 cubic-foot assembly, 600 CFM	140609	140607	A74
Pressure vessel, 3.5 cubic-foot assembly, 900 CFM	140610	140608	A74
Sight glasses for 1.5 cubic-foot pressure vessel (two required)	545471	545471	A72
Sight glasses for 3.5 cubic-foot pressure vessel (two required)	545493	545493	A72
Sure-Flo® valve, automatic (included with FaStrip®)	290188	290188	A73

### Suction Cabinet Options

Gun holder, fixed	140400	140400	A75
Gun package, four guns (adds three guns)	140349	140353	A75
Gun package, three guns (adds two guns)	140348	140352	A75
Gun package, two guns (adds one gun)	140347	140351	A75
KLEEN™ package	140358	140393	A75
Nozzle, ⅝" boron	502081	502081	A57
Nozzle, ⅝" Di-Carb™	501341	501341	A57

continued on next page



# Options: Pro-Finish® Systems

## 4848 Cabinets including Ergo-Blast and FaStrip®—continued

	FACTORY INSTALLED	CUSTOMER INSTALLED	SEE PAGE
<b>Dust Collector Options for DCM-200 (600 CFM)</b>			
Bag shaker, automatic electric, 115 volts	140340	140390	A65
Bag shaker, automatic pneumatic	140683	140684	A65
HEPA filter	140215	140215	A65
HEPA filter, pressure differential gauge assembly	140221	140221	A65
Leg extension kit	140180	140180	A65
Lid assembly for 55 gallon drum	140255	140255	A65
Manometer	140344	140398	A65
Sound attenuator/damper	140361	140361	A65
<b>Dust Collector Options for CDC-6 (600 CFM)</b>			
HEPA filter	140215	140215	A66
HEPA filter, pressure differential gauge assembly	140221	140221	A66
Photohelic cartridge cleaning, automatic pulse	140900	140900	A66
Leg extension kit	140185	140185	A66
Lid assembly for 55 gallon drum	140155	140155	A66
Sound attenuator/damper	140361	140361	A66
<b>Dust Collector Options for DCM-200A (900 CFM)</b>			
Bag shaker, automatic electric, 115 volts	140340	140390	A65
Bag shaker, automatic pneumatic	140683	140684	A65
HEPA filter	140215	140215	A65
HEPA filter, pressure differential gauge assembly	140221	140221	A65
Leg extension kit	140180	140180	A65
Lid assembly for 55 gallon drum	140255	140255	A65
Manometer	140344	140398	A65
Sound attenuator/damper	140769	140769	A65
<b>Dust Collector Options for CDC-9 (900 CFM)</b>			
HEPA filter	140215	140215	A66
HEPA filter, pressure differential gauge assembly	140221	140221	A66
Photohelic cartridge cleaning, automatic pulse	140900	140900	A66
Leg extension kit	140185	140185	A66
Lid assembly for 55 gallon drum	140155	140155	A66
Sound attenuator/damper	140769	140769	A66
<b>Higher Volume Ventilation Options</b>			
1200 CFM equipment	Call factory	Call factory	—





## 4848 SafeStrip™ and Single-Pass Models (600 and 900 CFM)

	FACTORY INSTALLED	CUSTOMER INSTALLED	SEE PAGE
<b>Three-Phase Electrical Options (600 CFM)</b>			
<b>Single Source:</b>			
208 Volt, 60 Hertz	139047	139122	A36
230 Volt, 60 Hertz	139048	139123	A36
460 Volt, 60 Hertz	139049	139124	A36
575 Volt, 60 Hertz	139050	139125	A36
380 Volt, 50 Hertz	139051	139126	A36
<b>Three-Phase Electrical Options (900 CFM)</b>			
<b>Single Source:</b>			
208 Volt, 60 Hertz	139052	139127	A36
230 Volt, 60 Hertz	139053	139128	A36
460 Volt, 60 Hertz	139054	139129	A36
575 Volt, 60 Hertz	139055	139130	A36
380 Volt, 50 Hertz	139056	139131	A36
<b>Cabinet Extended-Wear Options</b>			
Black curtain for cone	510771	510851	A59
Black curtains for front wall	140640	140641	A59
Black curtains for interior sides and back wall	510811	510891	A59
Conveying hose, heavy duty, 6" x 9', 600 CFM	140338	140354	A67
Conveying hose, heavy duty, 6" x 12', 900 CFM	140339	140355	A67
White curtain for cone	140552	140560	A59
White curtains for front wall	140577	140973	A59
White curtains for interior sides and back wall	140556	140564	A59
Window protector, plastic	509191	509191	A64
Window protector, screen	509201	509201	A64
<b>Cabinet Options</b>			
2'n'1 door basket, coated	140404	140405	A58
2'n'1 door basket, standard (uncoated)	140342	140406	A58
Antistatic strap	510411	510411	A58
Armrest assembly	140596	140596	A58
Blast hose, 1/2", top entry	140878	140879	A49
Blast hose, 3/4", top entry, with 1/4" Di-Carb™ nozzle	140635	140634	A66
Boron restrictor for MG-78 valve (not available with SafeStrip™)	290184	290184	A50
Cone, 60 degree, for pressure vessel (not available with SafeStrip™)	505002	140060	A68
Door locking clamp, right side with timer	140628	140630	A58
Door locking clamp, right side without timer	140624	140626	A58
Door locking clamp, two doors with timer	140629	140631	A58
Door locking clamp, two doors without timer	140625	140627	A58
Door sill package for one door	140726	761561	A69
Glove hole plugs	140623	140622	A58
HEPA filter, cabinet inlet	140190	140190	A58
Media sensor, low level (not available with SafeStrip™)	140361	140361	A70
Nozzle, 3/16" boron	502032	502032	A49
Nozzle, 3/16" Di-Carb™	501282	501282	A49
Nozzle holder, fixed	140401	140401	A71
Oscillator assembly (specify horizontal or vertical)	140424	140402	A59
Safety matting (specify length)	509002	509002	A60
Sight glasses for 1.5 cubic-foot pressure vessel (two required)	545471	545471	A72

*continued on next page*



# Options: Pro-Finish® Systems

## 4848 SafeStrip™ and Single-Pass Models—continued

	FACTORY INSTALLED	CUSTOMER INSTALLED	SEE PAGE
Sight glasses for 3.5 cubic-foot pressure vessel (two required)	545493	545493	A72
Sound attenuator	140597	140597	—
System security key-lock	140864	140864	A60
Timer package, electric	140536	140535	A60
Timer package, mechanical	140420	140421	A60
Turntable, manual, 18" stationary	140422	140422	A60
Turntable, manual, 18" stationary, low profile	140574	140574	A60
Turntable, manual, 24" rolling, includes inside/outside tracks	140322	140322	A60
Turntable, manual, 24" stationary, low profile	140502	140502	A60
Turntable, manual, 36" rolling, includes inside/outside tracks	140323	140323	A60
Turntable, manual, 36" stationary, low profile	140503	140503	A60
Turntable, powered, 24" rolling, includes inside/outside tracks <b>(Consult factory!)</b>	140364	140364	A60
Turntable, powered, 24" stationary, low profile	140504	140504	A60
Turntable, powered, 36" rolling, includes inside/outside tracks <b>(Consult factory!)</b>	140365	140365	A60
Turntable, powered, 36" stationary, low profile	140505	140505	A60
Vertical door	140489	140489	A63

### Dust Collector Options for DCM-200 (600 CFM)

Bag shaker, automatic electric, 115 volts	140340	140390	A65
Bag shaker, automatic pneumatic	140683	140684	A65
HEPA filter	140215	140215	A65
HEPA filter, magnetic gauge assembly	140221	140221	A65
Leg extension kit	140180	140180	A65
Lid assembly for 55 gallon drum	140255	140255	A65
Manometer	140344	140398	A65
Sound attenuator/damper	140361	140361	A65

### Dust Collector Options for CDC-6 (600 CFM)

HEPA filter	140215	140215	A66
HEPA filter, pressure differential gauge assembly	140221	140221	A66
Photohelic cartridge cleaning, automatic pulse	140900	140900	A66
Leg extension kit	140185	140185	A66
Lid assembly for 55 gallon drum	140155	140155	A66
Sound attenuator/damper	140361	140361	A66

### Dust Collector Options for DCM-200A (900 CFM)

Bag shaker, automatic electric, 115 volts	140340	140390	A65
Bag shaker, automatic pneumatic	140683	140684	A65
HEPA filter	140215	140215	A65
HEPA filter, pressure differential gauge assembly	140221	140221	A65
Leg extension kit	140180	140180	A65
Lid assembly for 55 gallon drum	140255	140255	A65
Manometer	140344	140398	A65
Sound attenuator/damper	140769	140769	A65

### Dust Collector Options for CDC-9 (900 CFM)

HEPA filter	140215	140215	A66
HEPA filter, pressure differential gauge assembly	140221	140221	A66
Photohelic cartridge cleaning, automatic pulse	140900	140900	A66
Leg extension kit	140185	140185	A66
Lid assembly for 55 gallon drum	140155	140155	A66
Sound attenuator/damper	140769	140769	A66

### Higher Volume Ventilation Options

1200 CFM equipment	Call factory	Call factory	—
--------------------	--------------	--------------	---



## Options: Pro-Finish® Systems

### 6060 Cabinets including Ergo-Blast and FaStrip® (900 CFM)

	FACTORY INSTALLED	CUSTOMER INSTALLED	SEE PAGE
<b>Three-Phase Electrical Options (900 CFM)</b>			
<b>Single Source:</b>			
208 Volt, 60 Hertz	139052	139127	A36
230 Volt, 60 Hertz	139053	139128	A36
460 Volt, 60 Hertz	139054	139129	A36
575 Volt, 60 Hertz	139055	139130	A36
380 Volt, 50 Hertz	139056	139131	A36
<b>Cabinet Extended-Wear Options</b>			
Black curtain for cone *(Call about Ergo-Blast.)	510781	510861*	A59
Black curtains for front wall *(Call about Ergo-Blast.)	140638	140639*	A59
Black curtains for interior sides and back wall	510921	510901	A59
Conveying hose, heavy duty, 6" x 12', 900 CFM	140339	140355	A67
White curtain for cone *(Call about Ergo-Blast.)	140553	140561*	A59
White curtains for front wall *(Call about Ergo-Blast.)	140977	140976*	A59
White curtains for interior sides and back wall	140557	140565	A59
Window protector, plastic	509191	509191	A64
Window protector, screen	509201	509201	A64
<b>Reclaimer Extended-Wear Options (900 CFM)</b>			
Ultrawear lining	526193	N/A	A67
Urethane spray lining	525891	N/A	A67
Wear plate	514491	514521	A67
<b>Cabinet Options</b>			
2'n'1 door basket, coated	140404	140405	A58
2'n'1 door basket, standard (uncoated)	140342	140406	A58
Antistatic strap	510411	510411	A58
Armrest assembly (included with Ergo-Blast)	140596	140596	A58
Door locking clamp, right side with timer	140628	140630	A58
Door locking clamp, right side without timer	140624	140626	A58
Door locking clamp, two doors with timer	140629	140631	A58
Door locking clamp, two doors without timer	140625	140627	A58
Glove hole plugs	140623	140622	A58
Magnetic separator (included with FaStrip®)	511572	511572	A58
Oscillator assembly (specify horizontal or vertical)	140424	140402	A59
Safety matting (specify length)	509002	509002	A60
Sound attenuator (included with Ergo-Blast)	140597	140597	—
System security key-lock	140864	140864	A60
Timer package, electric	140536	140535	A60
Timer package, mechanical	140420	140421	A60
Turntable, manual, 18" stationary	140422	140422	A60
Turntable, manual, 18" stationary, low profile	140574	140574	A60
Turntable, manual, 24" rolling, includes inside/outside tracks	140324	140324	A60
Turntable, manual, 24" stationary, low profile	140502	140502	A60
Turntable, manual, 36" rolling, includes inside/outside tracks	140325	140325	A60
Turntable, manual, 36" stationary, low profile	140503	140503	A60
Turntable, powered, 24" rolling, includes inside/outside tracks <b>(Consult factory!)</b>	140375	140375	A60
Turntable, powered, 24" stationary, low profile (not available with Ergo-Blast)	140504	140504	A60
Turntable, powered, 36" rolling, includes inside/outside tracks <b>(Consult factory!)</b>	140376	140376	A60
Turntable, powered, 36" stationary, low profile (not available with Ergo-Blast)	140505	140505	A60

continued on next page



# Options: Pro-Finish® Systems

## 6060 Cabinets including Ergo-Blast and FaStrip®—continued

	FACTORY INSTALLED	CUSTOMER INSTALLED	SEE PAGE
Vertical door	140488	140488	A63
Vibrating reclaiming screen assembly (included with FaStrip®)	140335	140419	A64

### Pressure Cabinet Options

Blast hose, ½", top entry	140878	140879	A49
Blast hose, ¾", top entry, with ¼" Di-Carb™ nozzle	140635	140634	A68
Boron restrictor for MG-78 valve	290184	290184	A50
Cone, 60 degree, for pressure vessel	505002	140060	A68
Constant pressure control assembly	140523	Call factory	A68
Door sill package for one door (two included with Ergo-Blast)	140728	761581	A69
Fine tuning package	140511	140512	A69
Fine tuning package with choke	140509	140510	A69
Media regulator, aerated	140374	140360	A70
Media sensor, low level	140381	Call factory	A70
MG-78 CR valve (included with FaStrip®)	290234	290232	A71
Nozzle, ⅜" boron	502032	502032	A49
Nozzle, ⅜" Di-Carb™	501282	501282	A49
Nozzle holder, fixed	140401	140401	A71
Nozzles, second nozzle upgrade	140605	140604	A72
Pressure vessel, 3.5 cubic-foot assembly, 900 CFM	140610	140608	A74
Sight glasses for 1.5 cubic-foot pressure vessel (two required)	545471	545471	A72
Sight glasses for 3.5 cubic-foot pressure vessel (two required)	545493	545493	A72
Sure-Flo® valve, automatic (included with FaStrip®)	290188	290188	A73

### Suction Cabinet Options

Gun holder, fixed	140400	140400	A75
Gun package, four guns (adds three guns)	140349	140353	A75
Gun package, three guns (adds two guns)	140348	140352	A75
Gun package, two guns (adds one gun)	140347	140351	A75
KLEEN™ package	140359	140394	A75
Nozzle, ⅝" boron	502081	502081	A57
Nozzle, ⅝" Di-Carb™	501341	501341	A57

### Dust Collector Options for DCM-200A (900 CFM)

Bag shaker, automatic electric, 115 volts	140340	140390	A65
Bag shaker, automatic pneumatic	140683	140684	A65
HEPA filter	140215	140215	A65
HEPA filter, pressure differential gauge assembly	140221	140221	A65
Leg extension kit	140180	140180	A65
Lid assembly for 55 gallon drum	140255	140255	A65
Manometer	140344	140398	A65
Sound attenuator	140769	140769	A65

### Dust Collector Options for CDC-9 (900 CFM)

HEPA filter	140215	140215	A66
HEPA filter, pressure differential gauge assembly	140221	140221	A66
Photohelic cartridge cleaning, automatic pulse	140900	140900	A66
Leg extension kit	140185	140185	A66
Lid assembly for 55 gallon drum	140155	140155	A66
Sound attenuator	140769	140769	A66

### Higher Volume Ventilation Options

1200 CFM equipment	Call Factory	Call Factory	—
--------------------	--------------	--------------	---





## 6060 SafeStrip™ and Single-Pass Models (900 CFM)

	FACTORY INSTALLED	CUSTOMER INSTALLED	SEE PAGE
<b>Three-Phase Electrical Options (900 CFM)</b>			
<b>Single Source:</b>			
208 Volt, 60 Hertz	139052	139127	A36
230 Volt, 60 Hertz	139053	139128	A36
460 Volt, 60 Hertz	139054	139129	A36
575 Volt, 60 Hertz	139055	139130	A36
380 Volt, 50 Hertz	139056	139131	A36
<b>Cabinet Extended-Wear Options</b>			
Black curtain for cone	510781	510861	A59
Black curtains for front wall	140638	140639	A59
Black curtains for interior sides and back wall	510921	510901	A59
Conveying hose, heavy duty, 6" x 12', 900 CFM	140339	140355	A59
White curtain for cone	140553	140561	A59
White curtains for front wall	140977	140976	A59
White curtains for interior sides and back wall	140557	140565	A59
Window protector, plastic	509191	509191	A64
Window protector, screen	509201	509201	A64
<b>Cabinet Options</b>			
2'n'1 door basket, coated	140404	140405	A58
2'n'1 door basket, standard (uncoated)	140342	140406	A58
Antistatic strap	510411	510411	A58
Armrest assembly	140596	140596	A58
Blast hose, ½", top entry	140878	140879	A49
Blast hose, ¾", top entry, with ¼" Di-Carb™ nozzle	140635	140634	A66
Boron restrictor for MG-78 valve (not available with SafeStrip™)	290184	290184	A50
Cone, 60 degree, for pressure vessel (not available with SafeStrip™)	505002	140060	A68
Door locking clamp, right side with timer	140628	140630	A58
Door locking clamp, right side without timer	140624	140626	A58
Door locking clamp, two doors with timer	140629	140631	A58
Door locking clamp, two doors without timer	140625	140627	A58
Door sill package for one door	140728	761581	A69
Glove hole plugs	140623	140622	A58
HEPA filter, cabinet inlet	140752	140752	A58
Media sensor, low level (not available with SafeStrip™)	140361	140361	A70
Nozzle, ⅜" boron	502032	502032	A49
Nozzle, ⅜" Di-Carb™	501282	501282	A49
Nozzle holder, fixed	140401	140401	A71
Oscillator assembly (specify horizontal or vertical)	140424	140402	A59
Safety matting (specify length)	509002	509002	A60
Sight glasses for 1.5 cubic-foot pressure vessel (two required)	545471	545471	A72
Sight glasses for 3.5 cubic-foot pressure vessel (two required)	545493	545493	A72
Sound attenuator	140597	140597	—
System security key-lock	140864	140864	A60
Timer package, electric	140536	140535	A60
Timer package, mechanical	140420	140421	A60
Turntable, manual, 18" stationary	140422	140422	A60
Turntable, manual, 18" stationary, low profile	140574	140574	A60
Turntable, manual, 24" rolling, includes inside/outside tracks	140324	140324	A60

continued on next page





# Options: Pro-Finish® Systems

## 6060 SafeStrip™ and Single-Pass Models—continued

	FACTORY INSTALLED	CUSTOMER INSTALLED	SEE PAGE
Turntable, manual, 24" stationary, low profile	140502	140502	A60
Turntable, manual, 36" rolling, includes inside/outside tracks	140325	140325	A60
Turntable, manual, 36" stationary, low profile	140503	140503	A60
Turntable, powered, 24" rolling, includes inside/outside tracks <b>(Consult factory!)</b>	140375	140375	A60
Turntable, powered, 24" stationary, low profile	140504	140504	A60
Turntable, powered, 36" rolling, includes inside/outside tracks <b>(Consult factory!)</b>	140376	140376	A60
Turntable, powered, 36" stationary, low profile	140505	140505	A60
Vertical door	140488	140488	A63

### Dust Collector Options for DCM-200A (900 CFM)

Bag shaker, automatic electric, 115 volts	140340	140390	A65
Bag shaker, automatic pneumatic	140683	140684	A65
HEPA filter	140215	140215	A65
HEPA filter, pressure differential gauge assembly	140221	140221	A65
Leg extension kit	140180	140180	A65
Lid assembly for 55 gallon drum	140255	140255	A65
Manometer	140344	140398	A65
Sound attenuator/damper	140769	140769	A65

### Dust Collector Options for CDC-9 (900 CFM)

HEPA filter	140215	140215	A66
HEPA filter, pressure differential gauge assembly	140221	140221	A66
Photohelic cartridge cleaning, automatic pulse	140900	140900	A66
Leg extension kit	140185	140185	A66
Lid assembly for 55 gallon drum	140155	140155	A66
Sound attenuator/damper	140769	140769	A66

### Higher Volume Ventilation Options

1200 CFM equipment	Call factory	Call factory	—
--------------------	--------------	--------------	---





## 60120 Twin Cabinets (900 CFM)

	FACTORY INSTALLED	CUSTOMER INSTALLED	SEE PAGE
--	----------------------	-----------------------	-------------

*Two items required for upgrades of both cabinets.*

### Three-Phase Electrical Options (900 CFM)

#### Single Source:

208 Volt, 60 Hertz	139052	139127	A36
230 Volt, 60 Hertz	139053	139128	A36
460 Volt, 60 Hertz	139054	139129	A36
575 Volt, 60 Hertz	139055	139130	A36
380 Volt, 50 Hertz	139056	139131	A36

### Cabinet Extended-Wear Options

Black curtain for cone	510781	510861	A59
Black curtains for front wall	140638	140639	A59
Black curtains for interior sides and back wall	510921	510901	A59
Conveying hose, heavy duty, 6" x 12', 900 CFM	140339	140355	A67
White curtain for cone	140553	140561	A59
White curtains for front wall	140638	140976	A59
White curtains for interior sides and back wall	140557	140565	A59
Window protector, plastic	509191	509191	A64
Window protector, screen	509201	509201	A64

### Reclaimer Extended-Wear Options (900 CFM)

Ultrawear lining	526193	N/A	A67
Urethane spray lining	525891	N/A	A67
Wear plate	514491	514521	A67

### Cabinet Options

2'n'1 door basket, coated	140404	140405	A58
2'n'1 door basket, standard (uncoated)	140342	140406	A58
Antistatic strap	510411	510411	A58
Armrest assembly (included with Ergo-Blast)	140596	140596	A58
Door locking clamp, right side with timer	140628	140630	A58
Door locking clamp, right side without timer	140624	140626	A58
Door locking clamp, two doors with timer	140629	140631	A58
Door locking clamp, two doors without timer	140625	140627	A58
Glove hole plugs	140623	140622	A58
HEPA filter, cabinet inlet	140752	140752	A58
Magnetic separator (included with FaStrip®)	511572	511572	A58
Oscillator assembly (specify horizontal or vertical)	140424	140402	A59
Safety matting (specify length)	509002	509002	A60
Sound attenuator (included with Ergo-Blast)	140597	140597	—
System security key-lock	140864	140864	A60
Timer package, electric	140536	140535	A60
Timer package, mechanical	140420	140421	A60
Turntable, manual, 18" stationary	140422	140422	A60
Turntable, manual, 18" stationary, low profile	140574	140574	A60
Turntable, manual, 24" rolling, includes inside/outside tracks	140324	140324	A60
Turntable, manual, 24" stationary, low profile	140502	140502	A60
Turntable, manual, 36" rolling, includes inside/outside tracks	140325	140325	A60
Turntable, manual, 36" stationary, low profile	140503	140503	A60
Turntable, powered, 24" stationary, low profile <b>(Consult factory!)</b>	140504	140504	A60

*continued on next page*



# Options: Pro-Finish® Systems

## 60120 Cabinets—continued

	FACTORY INSTALLED	CUSTOMER INSTALLED	SEE PAGE
Turntable, powered, 36" stationary, low profile ( <b>Consult factory!</b> )	140505	140505	A60
Vertical door	140488	140488	A63
Vibrating reclaimer screen assembly (included with FaStrip®)	140335	140419	A64

### Pressure Cabinet Options

Blast hose, ½", top entry	140878	140879	A49
Blast hose, ¾", top entry, with ¼" Di-Carb™ nozzle	140635	140634	A68
Boron restrictor for MG-78 valve	290184	290184	A50
Cone, 60 degree, for pressure vessel	505002	140060	A68
Constant pressure control assembly	140523	Call Factory	A68
Door sill package for one door (two included with Ergo-Blast)	140728	761581	A69
Fine tuning package	140511	140512	A69
Fine tuning package with choke	140509	140510	A69
Media regulator, aerated	140374	140360	A70
Media sensor, low level	140381	Call Factory	A70
MG-78 CR valve (included with FaStrip®)	290234	290232	A71
Nozzle, ¼" boron	502032	502032	A49
Nozzle, ¼" Di-Carb™	501282	501282	A49
Nozzle holder, fixed	140401	140401	A71
Nozzles, second nozzle upgrade	140605	140604	A72
Pressure vessel, 3.5 cubic-foot assembly, 900 CFM	140610	140608	A74
Sight glasses for 1.5 cubic-foot pressure vessel (two required)	545471	545471	A72
Sight glasses for 3.5 cubic-foot pressure vessel (two required)	545493	545493	A72
Sure-Flo® valve, automatic (included with FaStrip®)	290188	290188	A73

### Suction Cabinet Options

Gun holder, fixed	140400	140400	A75
Gun package, four gun upgrade (adds three guns)	140349	140353	A75
Gun package, three gun upgrade (adds two guns)	140348	140352	A75
Gun package, two gun upgrade (adds one gun)	140347	140351	A75
KLEEN™ package	140359	140394	A75
Nozzle, ⅝" boron	502081	502081	A57
Nozzle, ⅝" Di-Carb™	501341	501341	A57

### Dust Collector Options for DCM-200A (900 CFM)

Bag shaker, automatic electric, 115 volts	140340	140390	A65
Bag shaker, automatic pneumatic	140683	140684	A65
HEPA filter	140215	140215	A65
HEPA filter, pressure differential gauge assembly	140221	140221	A65
Leg extension kit	140180	140180	A65
Lid assembly for 55 gallon drum	140255	140255	A65
Manometer	140344	140398	A65
Sound attenuator	140769	140769	A65

### Dust Collector Options for CDC-9 (900 CFM)

HEPA filter	140215	140215	A66
HEPA filter, pressure differential gauge assembly	140221	140221	A66
Photohelic cartridge cleaning, automatic pulse	140900	140900	A66
Leg extension kit	140185	140185	A66
Lid assembly for 55 gallon drum	140155	140155	A66
Sound attenuator	140769	140769	A66

### Higher Volume Ventilation Options

1200 CFM equipment	Call factory	Call factory	—
--------------------	--------------	--------------	---





# Pro-Finish® Parts

## Pro-Finish® Electrical Options

### Electrical Requirements

Pro-Finish® systems are wired to interface with the electrical sources described immediately below.

System Airflow	Horsepower	Nominal Voltage/Frequency
400 CFM	1 hp	115V/60Hz/1Ph
600 CFM	1½ hp	230V/60Hz/1Ph (3 wire)
900 CFM	2 hp	230V/60Hz/1Ph (3 wire)
1,200 CFM	5 hp	230-460V/50* -60Hz/3Ph (3 wire)

\* 50 Hertz systems with reclaimers may not convey heavier media, especially when using multiple guns, large nozzles and at high altitudes. Consult factory.

**IMPORTANT!** Systems must be wired at the factory to match the customer's electrical supply. If the electrical supply at the installation site differs from those listed above, specify the appropriate part number(s) shown on the next two pages.

### Three-Phase Options

Three-phase electrical options are available in two variations:

**Single source** packages, including a three-phase blower, a motor starter, a transformer and enclosures, and Empire's **Industrial Electrical Package (I.E.P.)** conform to NFPA 79 Electrical Standard for Industrial Machinery. The many safety and convenience features in the I.E.P. include:

- Control transformer
- I.E.C. motor starter with overload relay
- Fuse protected wiring
- NEMA 12 enclosures with panels
- Three-phase blower motor (3600 RPM)
- Green, oil-tight ON push button
- Red, oil-tight OFF mushroom-head push button
- Labels for panel-mounted devices
- Machine nameplate
- Allen-Bradley components where applicable

If customer's specification differs from the I.E.P. described above, send the specification to our Modified Cabinet Department for evaluation and a price quotation.

### Part Numbers for Three-Phase Options

NOMINAL VOLTAGE/FREQUENCY	208V/60Hz	230V/60Hz	460V/60Hz	575V/60Hz	380V/50Hz*
<b>400 CFM/1 Horsepower</b>	<b>PART NUMBERS</b>				
Single source, Factory installed	139042	139043	139044	139045	139046
Single source, Customer installed†	139117	139118	139119	139120	139121
Industrial Equipment Package (I.E.P.)	139057	139058	139059	139096	NA
<b>600 CFM/1½ Horsepower</b>					
Single source, Factory installed	139047	139048	139049	139050	139051
Single source, Customer installed†	139122	139123	139124	139125	139126
Industrial Equipment Package (I.E.P.)	139060	139061	139062	139097	NA
<b>900 CFM/2 Horsepower</b>					
Single source, Factory installed	139052	139053	139054	139055	139056
Single source, Customer installed†	139127	139128	139129	139130	139131
Industrial Equipment Package (I.E.P.)	139063	139064	139065	139098	NA
<b>1200 CFM/5 Horsepower</b>					
Single source, Factory installed	139088	139089	139090	139091	139092
Single source, Customer installed†	139132	139089	139133	139130	139131
Industrial Equipment Package (I.E.P.)	139093	139094	139095	139099	NA

\* 50 Hertz systems with reclaimers may not convey heavier media, especially when using multiple guns, large nozzles and at high altitudes. Consult factory.

† Customer installed part numbers apply if machine now has standard wiring. Customer installation is not recommended. Electrical parts are not returnable.

*continued on next page*

Never use silica sand in any Empire equipment.



# Parts: Pro-Finish® Electrical Options

## Part Numbers for Single-Phase Options

PART FUNCTION/DESCRIPTION	FACTORY INSTALLED PART NUMBER	CUSTOMER INSTALLED PART NUMBER
400 CFM/1 HP connection to <b>110V/50Hz*/1Ph</b> supply requires:		
<b>50 Hertz motor</b>	139138	NA
400 CFM/1 HP connection to <b>220V/50Hz*/1Ph</b> supply requires:		
<b>50 Hertz motor</b> for 3-wire supply	139039	NA
Add <b>Transformer .5KVA</b> for 2-wire supply†	139115	NA
400 CFM/1 HP connection to <b>230V/60Hz/1Ph (3 wire)</b> supply requires:		
<b>Rewiring</b>	139038	140474**
600 CFM/1½ HP connection to <b>115V/60Hz/1Ph</b> supply requires <b>30 Amp service</b> :		
<b>Contactors &amp; Rewiring</b>	139110	139111**
600 CFM/1½ HP connection to <b>220V/50Hz*/1Ph</b> supply requires:		
<b>50 Hertz motor</b> for 3-wire supply	139040	NA
Add <b>Transformer .5KVA</b> for 2-wire supply†	139115	NA
900 CFM/2 HP connection to <b>115V/60Hz/1Ph</b> supply requires <b>30 Amp service</b> :		
<b>Contactors &amp; Rewiring</b>	139110	139111**
900 CFM/2 HP connection to <b>220V/50Hz*/1Ph</b> supply requires:		
<b>50 Hertz motor</b> for 3-wire supply	139041	NA
Add <b>Transformer .5KVA</b> for 2-wire supply†	139115	NA

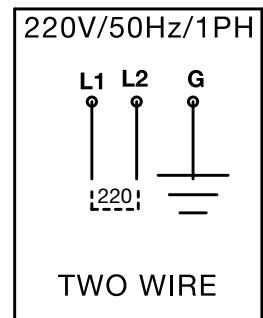
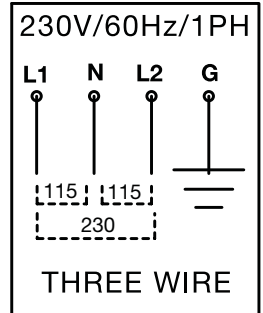

\* 50 Hertz systems with reclaimers may not convey heavier media, especially when using multiple guns, large nozzles and at high altitudes. Consult factory.

† Add **PN 139116** (1.0KVA Transformer upgrade) instead of PN 139115 if cabinet is equipped with a **2"n"1 door-basket attachment** (PNs 140342 or 140404).

\*\* Customer installed part numbers apply if machine now has standard wiring. Customer installation is not recommended. Electrical parts are not returnable.

## Dual Station Cabinets

Order two of each part number if option is required at both stations.

## NOTES on Electrical Components

- If no electrical disconnect is provided, the customer is responsible for providing appropriate disconnecting means adjacent to this equipment for each incoming power circuit. Each disconnect shall be of a type and rating suitable for the application. Refer to current editions of the **National Electrical Code (NFPA 70)** and the **Electrical Standard for Industrial Machinery (NFPA 79)**. Systems with a line cord plug do not require a disconnect. A disconnect is standard with Empire's **Industrial Electrical Package**.
- Interconnections between cabinet, dust collector and customer's utilities are to be supplied by installer.
- Some Pro-Finish options use separate 115 volt line cords with plugs.
- Electrical components cannot be returned to the factory for exchange.
- 50 Hertz systems with reclaimers may not convey heavier media, especially when using multiple guns, large nozzles, and at high altitudes. Consult factory.
- All three-phase systems are **three wire** (three-phase conductors and a ground).
- Consult factory for other electrical options, for conformance with customer electrical specifications, or if you have questions.

## See Operating Instructions for Proper Electrical Connection

Electrical connection at installation should be performed by a competent licensed electrician following local codes, standard safety procedures and proper installation instructions.

Never use silica sand in any Empire equipment.



# Parts: Pro-Finish® Cabinet Assemblies

## Guide to Part Numbers

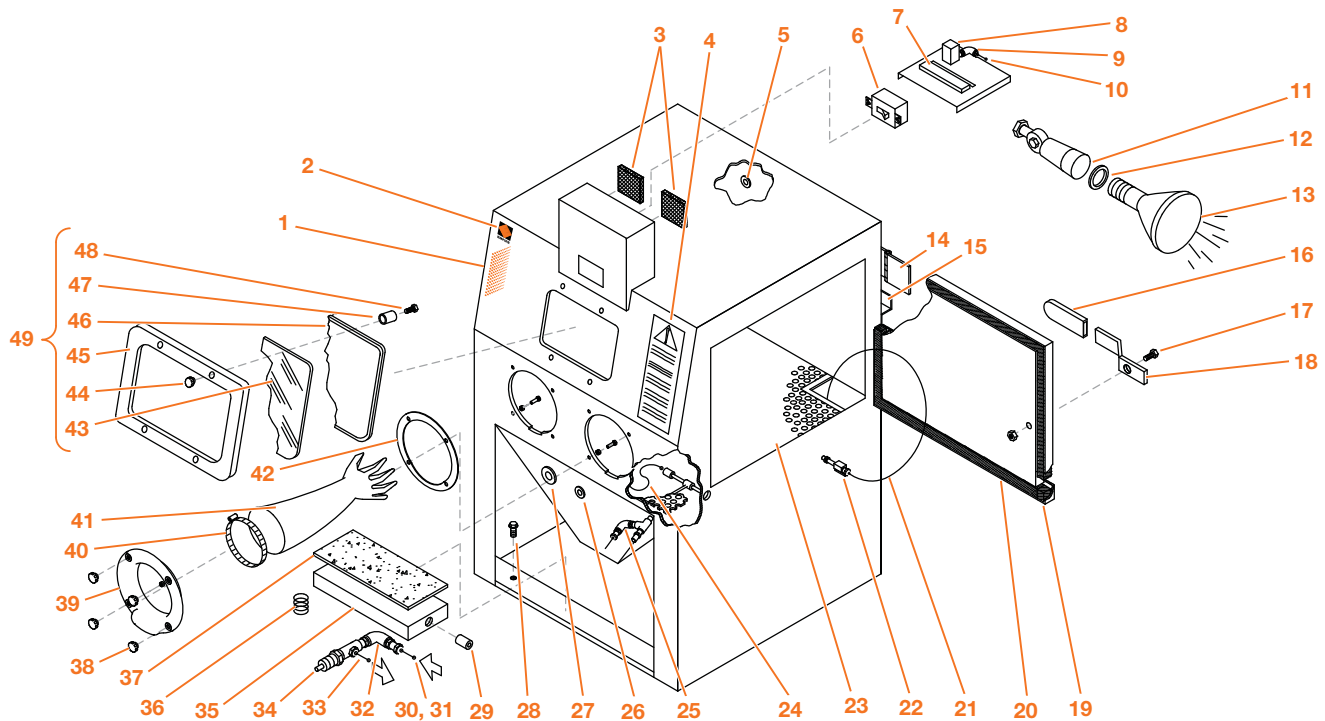

PRO-FINISH CABINET ASSEMBLY COMPONENTS		CABINET SIZE					
		2636	3648 3696	3660	3674	4848	6060 60120
Item	Description	PART NUMBERS					
1	Decal, orange dot strip (specify length)	564301	564301	564302	564301	564301	564302
	<i>Length in inches</i>	24"	30"	45"	30"	30"	45"
2	Paint, touch-up kit	564476	564476	564476	564476	564476	564476
3	Filter, Kleensweep™ inlet (2 required)	510491	510491	510491	510491	510491	510491
4	Decal, Instruction/Warnings	567391	567391	567391	567391	567391	567391
5	Grommet, blast hose, 1" x 1 3/8"	523931	523931	523931	523931	523931	523931
6	Switch, On/Off, 20 amp	534561	534561	534561	534561	534561	534561
7	Terminal strip, 15 pole	533611	533611	533611	533611	533611	533611
8	Solenoid valve, standard and CSA	519001	519001	519001	519001	519001	519001
9	Adapter, 1/4" tube x 1/8" MPT, 90°	520432	520432	520432	520432	520432	520432
10	Tubing, 1/4" OD (specify length)	510541	510541	510541	510541	510541	510541
11	Light fixture	532711	532711	532711	532711	532711	532711
12 *	Gasket, light bulb, 1 per bulb	580191	580191	580191	580191	580191	580191
13 †	Floodlight bulb	532701	532701	532701	532701	532701	532701
	Light guard (not shown)	509481	509481	509481	509481	509481	509491
	Light bar (not shown)	NA	NA	NA	NA	NA	770941
14	Hinge, 3"	509531	509531	509531	509531	509531	509531
15	Z-strip (reclaimer mount not shown)	760151	760161	760161	760161	760161	760171
16	Cover, handle	509571	509571	509571	509571	509571	509571
17	Bolt, door, 3/8"-16 x 2" SHCS	552151	552151	552151	552151	552151	552151
	Nut, 3/8"-16 ESNA	553952	553952	553952	553952	553952	553952
18	Handle, door	760361	760361	760361	760361	760361	760971
	Tie bar (not shown)	NA	NA	NA	NA	NA	760401
	Keeper (not shown)	760371	760371	760371	760371	760371	760371
19 †	Bumper, urethane	525041	525041	525041	525041	525041	525041
*	Gasket, 3/4" x 3/4"	525671	525681	525681	525681	525691	525701
20		(7', 2")	(10', 4")	(10', 4")	(10', 4")	(12', 7")	(15', 0")
*	Gasket, 3/4" x 3/4" (specify length)	524441	524441	524441	524441	524441	524441



# Parts: Pro-Finish® Cabinet Assemblies

PRO-FINISH CABINET ASSEMBLY COMPONENTS	2636	3648 3696	CABINET SIZE				
			3660	3674	4848	6060 60120	
Item	Description		PART NUMBERS				
21	Hose with fittings, dust-off gun	522631	522641	522661	526641	521481	522661
22	Gun, dust-off	509821	509821	509821	509821	509821	509821
	Spring (not shown)	511251	511251	511251	511251	511251	511251
23	Floor section, 2 required (4 needed for 3696 & 60120)	760541	760551	760571	760555	760561	760571
24	Interlock hose assembly: 3/8" air hose with clamps	520003	520003	520004	520003	520003	520004
25	Adapter, 1/4" x 1/8" MPT, 90°	520432	520432	520432	520432	520432	520432
26	Grommet, dust-off hose, 1/4" - 5/8" x 7/8"	523951	523951	523951	523951	523951	523951
27	Grommet, suction air hose, 3/4" x 1 1/16"	523921	523921	523921	523921	523921	523921
	Hole seal (pressure only)	536391	536391	536391	536391	536391	536391
28	Leveling bolt, 3/8" - 16 x 2" (4 required)	551742	551742	551742	551742	551742	551742
29	Brass bushing, treadle (2 required)	510501	510501	510501	510501	510501	510501
30	Tubing, 1/4" OD (specify length)	510541	510541	510541	510541	510541	510541
31	Connector, 1/8" MPT x 1/4" tube	520252	520252	520252	520252	520252	520252
32	Elbow, 1/8"	543822	543822	543822	543822	543822	543822
33	Barbed PTC, 1/4" tube x #10 - 32	521101	521101	521101	521101	521101	521101
34	† Valve, foot treadle, 3"	517221	517221	517221	517221	517221	517221
	† Barbed fitting, 1/4" tube x #10 - 32 with gasket	521101	521101	521101	521101	521101	521101
35	Foot treadle base	760041	760041	760041	518651	760041	760041
36	† Spring, treadle return (2 required)	510421	510421	510421	—	510421	510421
37	Grip/cover, treadle	524391	524391	524391	—	524391	524391
	Foot treadle assembly (includes items 29 through 37)	140160	140160	140160	140579**	140160	140160
Glove ring upgrade (includes items 38, 39, 42 and hardware)		140015	140015	140015	140015	140015	140015
38	Knob, 3/8" - 16 (4 required)	510461	510461	510461	510461	510461	510461
39	Glove flange	555036	555036	555036	555036	555036	555036
40	Clamp, 8", per glove	520561	520561	520561	520561	520561	520561
41 *	Gloves, pair	509891	509891	509891	509891	509891	509891
	Glove, left hand	510821	510821	510821	510821	510821	510821
42	Gasket, glove ring	523321	523321	523321	523321	523321	523321
43 *Δ	Safety glass, 14" x 22"	510401	510401	510401	510401	510401	510401
44	Knob, 3/8" - 16 (4 required)	510461	510461	510461	510461	510461	510461
45	Frame, window	760291	760291	760291	760291	760291	760291
	† Gasket, window, 6' section	524451	524451	524451	524451	524451	524451
46	Gasket, 1/4" x 1/4" (specify length)	525941	525941	525941	525941	525941	525941
	Gasket, 1/8" x 1/4" (specify length)	523551	523551	523551	523551	523551	523551
47	Spacer, window (4 required)	525931	525931	525931	525931	525931	525931
48	Bolt, 3/8" - 16 x 1 1/4"	551852	551852	551852	551852	551852	551852
49	Window kit (includes items 41 through 46)	140544	140544	140544	140544	140544	140544

\* Recommended spare part—Consumable wear item

† Essential component to prevent downtime

\*\* See Page A40, Item 1, for more information.

Δ Failure to replace glass with Empire safety glass could result in serious injury.



# Parts: Pro-Finish® Ergo-Blast Cabinet Assemblies

Ergo-Blast cabinets share most of the components shown on pages Pages A38 and A39 with other Pro-Finish® models. Ergo-Blast differences are shown below.

## Guide to Part Numbers

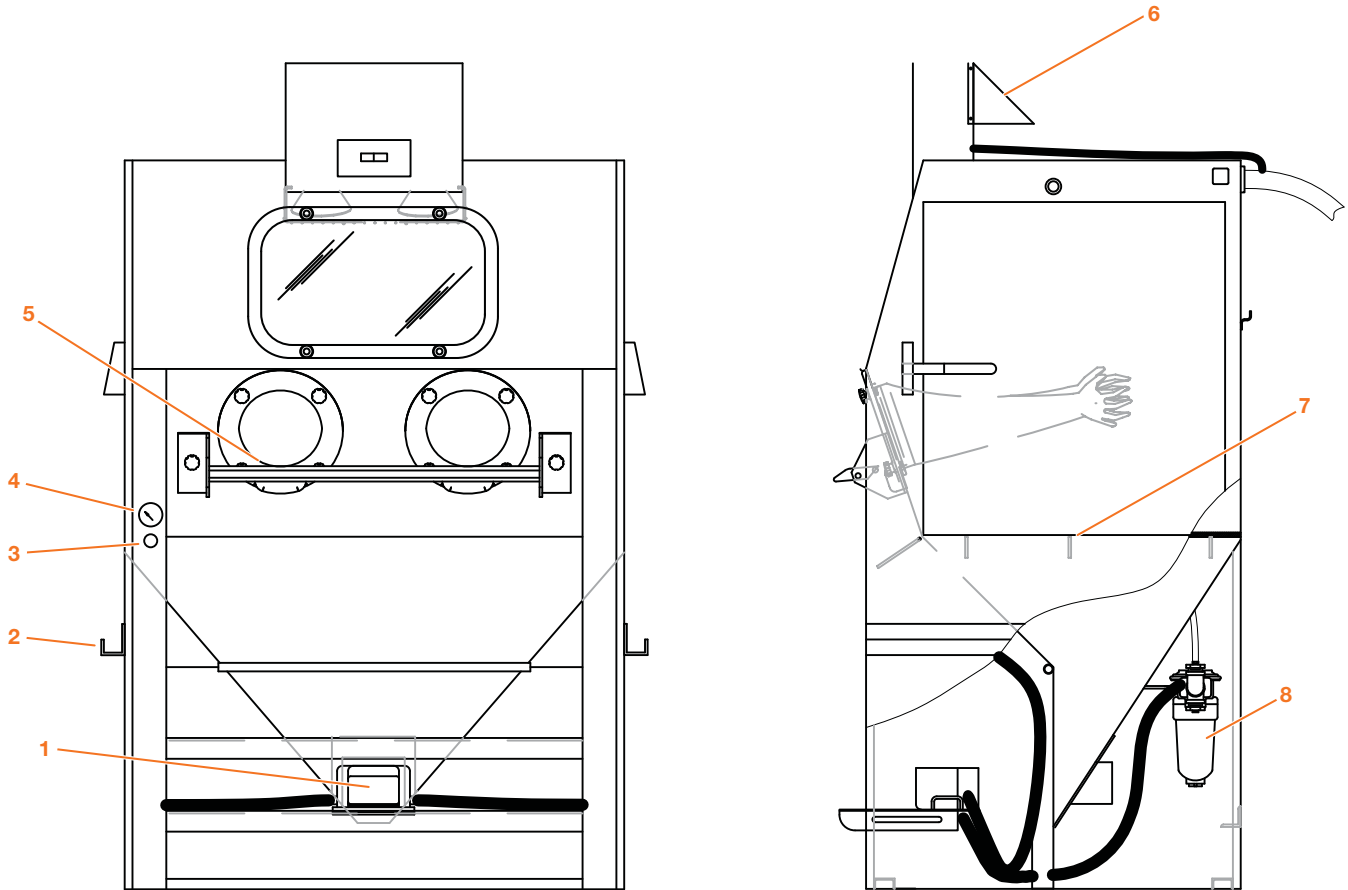

ERGO-BLAST CABINET ASSEMBLIES/PART VARIATIONS		CABINET SIZE				
		2636	3648 3696	3660	4848	6060
Item	Description	PART NUMBERS				
1	Foot treadle	518651	518651	518651	518651	518651
	Valve for foot treadle	518661	518661	518661	518661	518661
	Foot treadle assembly	140579	140579	140579	140579	140579
	Repair kit	518671	518671	518671	518671	518671
2	Door sill package for 1 door	140725	140726	140726	140727	140728
3	Pressure regulator	517613	517613	517613	517613	517613
4	Pressure gauge	550212	550212	550212	550212	550212
5	Arm rest assembly	140595	140596	140596	140596	140596
6	Cabinet sound attenuator	140597	140597	140597	140597	140597
7	Floor section (2 required)	770191	770201	760773	770211	760572
8	Pipe string assembly	(See page A47 for detail.)				



# Parts: Pro-Finish® Reclaimers

## Guide to Part Numbers

PRO-FINISH RECLAIMER COMPONENTS		400	600	900
Airflow Capacity (CFM)				1200
Item	Description	PART NUMBER		
1	Reclaimer body assembly (includes items 1 through 13)	140439	140440	140441
	Body assembly w/ 1 hp, 115V, 60Hz/1ph blower & bag	140438	NA	NA
2	Gasket, outlet flange (1 required)	524361	NA	NA
3	Outlet flange (6")	751501	NA	NA
4 *	Removable top	NA	766741	766751
5 †	Gasket, reclaimer to storage hopper and outlet flange	-	524371	525941
6 †	Gasket, reclaimer door	524331	524331	524331
7	Door, reclaimer	760721	760721	760721
8	Wing nut, 1/4" - 20	552392	552392	552392
9 †	Gasket, reclaimer to storage hopper	524371	524371	524371
10 †	Gasket, tuning band, solid	524342	524342	524342
	Gasket, tuning band, with slots	524341	524341	524341
11	Tuning band (steel part only), solid	767581	767581	767581
	Tuning band (steel part only), with slots	760701	760701	760701
12	Bolt, 1/4" - 20 x 2"	551782	551782	551782
13	Latch & keeper (requires welding)	509581	509581	509581
14	Screen, flat, 5/16", 13" OD	760711	760711	760711
15	Screen, fine 1 1/2" OD, 8 mesh	739041	739041	739041
	Screen, 1 1/2" OD, 4 mesh	739051	739051	739051
16	Bolt, 3/8" - 16 x 1" (8 required)	551852	551852	551852
17 *	Exhaust hose assembly for 1 cu. ft. pressure vessel (For pressure systems only)	522611	522611	522611
18	Plug, 1" NPT (For suction systems only)	544122	544122	544122

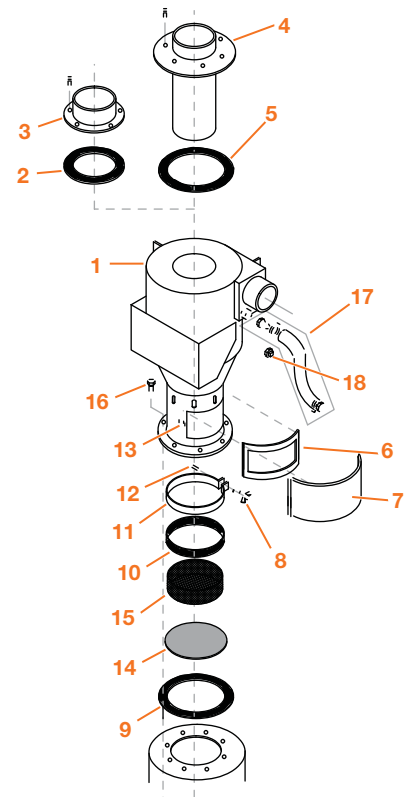

## Reclaimer Options

<b>Ultrawear lining</b>	NA	526183	526193
<b>Urethane lining</b>	NA	525861	525891
<b>Inlet wear plate (complete)</b>			
FACTORY INSTALLED	514471	514481	514491
CUSTOMER INSTALLED	514501	514511	514521
<b>Inlet wear plate (detail)</b>			
<b>A</b> Rubber band	524871	524881	524891
<b>B</b> Bolt, 3/8" - 16 x 2" (3 required)	553892	553892	553892
<b>C</b> Metal band	761601	761611	761621
<b>D</b> Bolt, 3/8" - 16 x 1 1/2" (3 required)	551262	551262	551262
<b>E</b> Nut, 3/8" - 16	552542	552542	552542

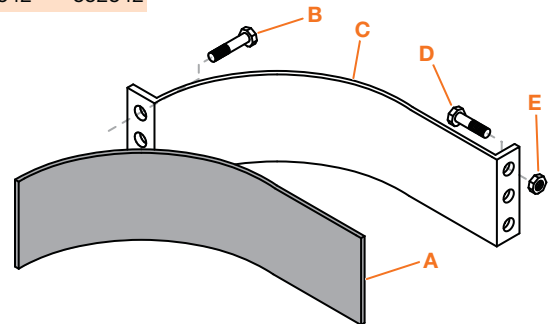

\* Recommended spare part—Consumable wear item  
 † Essential component to prevent downtime



# Parts: Pro-Finish® Dust Collectors, Bag House

## Guide to Part Numbers

For DCM-80A (PN 112000), DCR-80 (PN 112100), DCM-200 (PN 113000), DCM-200A (PN 113001) & DCM-200B (PN 113002)

### “DCR” & “DCM” SERIES COMPONENTS

Item	Description	PART#
1	Bolt, leveling, 3/8" - 16 x 2" (4 required)	553892
2	Latch and keeper (requires welding)	509581
3	Hose with fittings, 1/4" x 16', dust collector	523161
4	Adapter, 1/4" tube x 1/4" MPT (inside) Connector, brass, 1/4" MPT x 1/4" BALL (outside)	521081 520222
5	Bolt, 3/8" - 16 x 1 1/4" (6 required)	551852
6	Knob, 3/8" - 16 (6 required)	510461
7	Access door, dust collector	760851
8 †	Gasket, access door, 5/8" x 5/8", 103" section	525711
	Gasket, 5/8" x 5/8" (specify length)	525061
9 †	Valve, push-button, 1/8" NPT & #10 - 32, "3P"	517221
9	Barbed fitting, 1/4" tube x #10 - 32, 2 per assembly	521101
10	Adapter, 1/4" tube x 1/8" MPT, 90° (for air cylinder)	520432
10	Tubing, 1/4" OD (8' required)	510541
11 †	Air cylinder, standard collector and auto shaker	515981
	Air cylinder, auto-pneumatic bag shaker only	515771
12 †	Gasket, top plate, 1/8" x 1/4" (8' for DCM-80A; 12' for others)	523551
13	Blower & blower motors <b>(See page A45.)</b>	—
	Top plate, DCM-80A	760841
14	Top plate, DCM-200 & DCM-200A	760901
	Top plate, DCM-200B	760187
15	Bag-rack weldment (DCM-80A)	760861
	Bag-rack weldment (DCM-200A)	760921
16	Rubber bumper (8 required)	523541
17 *	Dust bag, cotton sateen (12 required for DCM-80A & DCR-80, 30 required for DCM-200, DCM-200A & DCM-200B)	515521
18	Decal, Instruction/Warning	567405
19	Ducting & adapters <b>(See page A46.)</b>	—
20	Adapter, 10 1/8" ID x 6" OD, DCM-200	761801
21 †	Gasket, clean-out door, dust collector	524351
	Decal, Empire logo	564305
	Decal, orange dot strip	564301
	Paint, 6 oz. aerosol, beige	564476

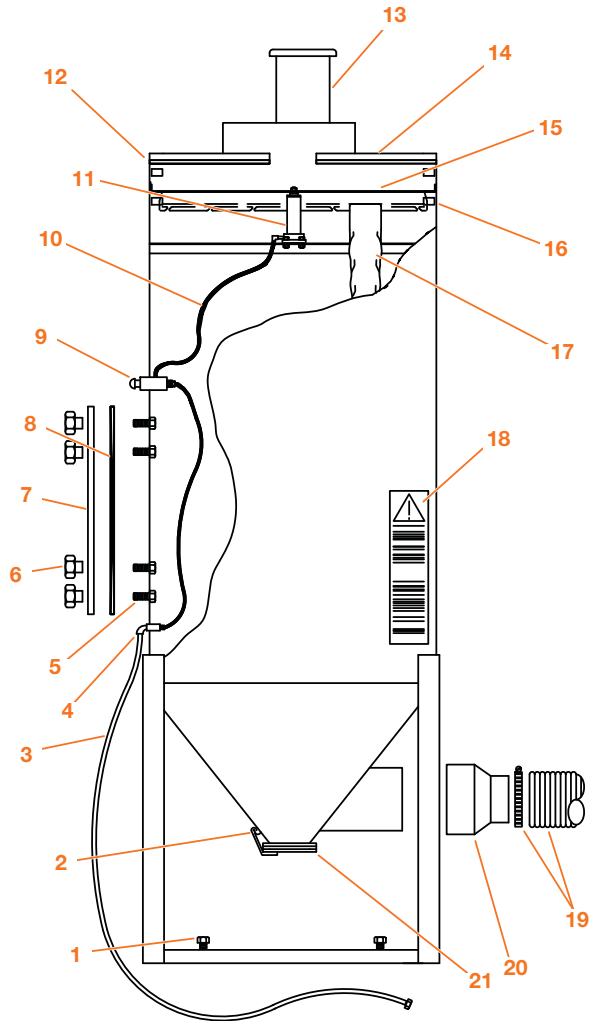

\* Recommended spare part—Consumable wear item

† Essential component to prevent downtime

### Bag-House Dust Collector Options

	PART NUMBERS		
	FACTORY INSTALLED	CUSTOMER INSTALLED	SEE PAGE
<b>Automatic bag shaker</b> cleans bags thoroughly every time the system is turned off.			
<b>Electric shaker</b> for all bag-house collectors	140340	140390	A65
<b>Pneumatic shaker</b> for DCM-80A	140685	140686	Call
<b>Pneumatic shaker</b> for DCM-200, DCM-200A & DCM-200B	140683	140684	Call
<b>HEPA filter</b> captures very fine particles.	140215	140215	—
<b>HEPA filter, pressure differential gauge assembly</b> informs operator regarding filter cleanliness.	140221	140221	—
<b>Leg extension kit</b> raises collector so larger collection drum can be placed underneath.			
<b>Kit</b> for DCM-80A	140170	140170	—
<b>Kit</b> for DCM-200, DCM-200A & DCM-200B	140180	140180	—
<b>Lid assembly</b> for 55 gallon drum attaches securely to clean-out door.	140155	140155	A65
<b>Manometer</b> keeps operator informed regarding bag cleanliness.	140344	140398	—
<b>Sound attenuator</b> reduces noise in the work place.			
<b>Attenuator/damper</b> for DCM-80A & DCM-200	140361	140361	—
<b>Attenuator/damper</b> for DCM-200A	140769	140769	—
<b>Attenuator/damper</b> for DCM-200B	140680	140680	—
<b>SuperSmooth</b> dust bags handle severe dust loading	516181	516181	—



# Parts: Pro-Finish® Dust Collectors, Cartridge

## Guide to Part Numbers

For CDC-6 (PN 113007), CDC-9 (PN 113011) & CDC-12 (PN 113013)

"CDC" SERIES COMPONENTS		
Item	Description	PART#
1	Bolt, leveling, 3/8" - 16 x 2" (4 required)	553892
2	16 gallon drum	504016
3	Lid for 16 gallon drum	850099-1
4	Gasket, dust drum lid, 5" (not shown)	800166
5	Dust hose, 4" (specify length)	522923
5	Hose clamp, 4" (2 required)	520531
	16 gallon drum assembly (includes items 2 through 5)	113015
6	Filter clamping screw	515526
7 †	Gasket, access door, 5/8" x 5/8", 103" section	525711
	Gasket, 5/8" x 5/8" (specify length)	525061
8	Access door, dust collector	760851
9	Knob, 3/8" - 16 (6 required)	510461
10	Bolt, 3/8" - 16 x 1 1/4" (6 required)	551852
	Empire logo	564305
11	Blower and blower motors ( <i>See page A45.</i> )	—
12	Diaphragm valve (2 required)	516350
	Top plate, CDC-6	760901
13	Top plate, CDC-9	760901
	Top plate, CDC-12	760187
14	Air supply assembly	140851
15 *	Cartridge filter (2 required)	515525
16	Decal, Instruction/Warning	567405
17	Mini-Helic package	550450
18	Ducting and adapters ( <i>See page A46.</i> )	—
19	Adapter, 10" ID x 6" OD for CDC-6	761801

\* Recommended spare part—Consumable wear item

† Essential component to prevent downtime

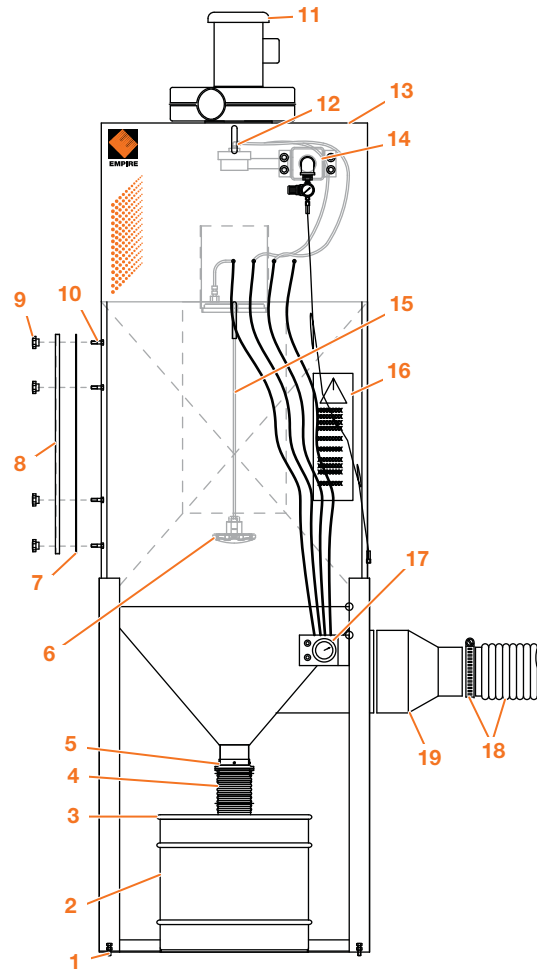

## Cartridge Dust Collector Options

	PART NUMBERS		
	FACTORY INSTALLED	CUSTOMER INSTALLED	SEE PAGE
<b>HEPA filter</b> captures very fine particles.	140215	140215	—
<b>HEPA filter, pressure differential gauge assembly</b> informs operator regarding filter cleanliness.	140221	140221	—
<b>Leg extension kit</b> raises collector so larger collection drum can be placed underneath.	140185	140185	—
<b>Lid assembly</b> for 55 gallon drum attaches securely to clean-out door.	140155	140155	A65
<b>Photohelic cartridge cleaning</b> improves system performance, saves operator time.	140900	140900	A66
<b>Sound attenuator/damper</b> reduces noise in the work place.			
Attenuator/damper for CDC-6	140361	140361	—
Attenuator/damper for CDC-9	140769	140769	—
Attenuator/damper for CDC-12	140680	140680	—



# Parts: Pro-Finish® Dust Collectors, SEM-2

## Guide to Part Numbers

SEM-2 COMPONENTS		
Item	Description	PART #
1	Blower assembly (See page A45.)	—
	Collector assembly	113036
2	Air supply assembly	140851
	Regulator/gauge	517612
3	Clamps	520531
4	Cover	516106
5	Waste pail	509611
6	Dust-drum platform	756682
7 †	Gasket, Neoprene, 9½" ID x 12" OD	515710
8 **	Gum rubber tube	523749
9 *	Filter assembly (2 required)	523523
10	Stand	770105
	Mini-helic package	550450
11	Gauge only	504201
	Push button valve only	520393
	Diaphragm valve, 2 required (not shown)	516329
	Rebuild kit, diaphragm valve (not shown)	516328

\* Recommended spare part—Consumable wear item

† Essential component to prevent downtime

**\*\*NOTE:** If the SEM dust outlet uses a 7" hose, contact Empire's Customer Service Department for replacement parts. If it uses a 4" hose, Part # 523749 is a direct replacement.

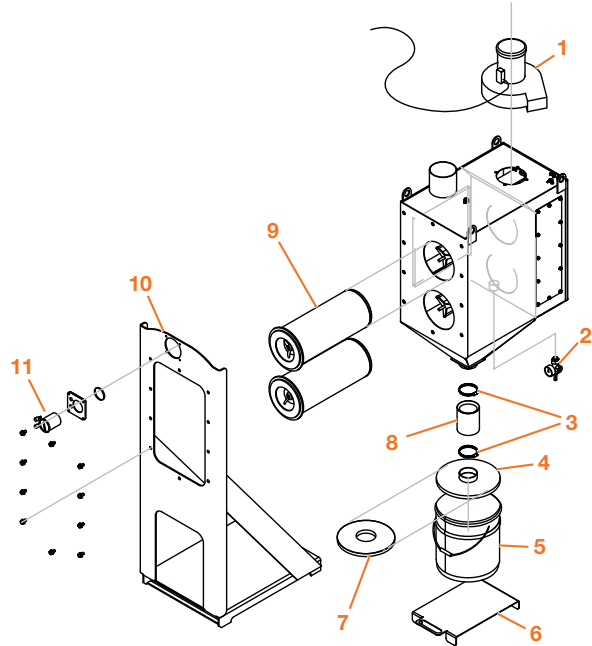

### SEM-2 Dust Collector Options

Photohelic cartridge cleaning (See page A66.)

PART #

140810



# Parts: Pro-Finish® Dust Bag

## Guide to Part Numbers

DUST BAG COMPONENTS		
Item	Description	PART NUMBER
1	Clamp, 4" adjustable	515765
2 *	Dust bag, 4" inlet, 30 sq. ft.	515841
3	Closure clamp	520461
	Blower assembly (See page A45.)	—

\* Recommended spare part—Consumable wear item

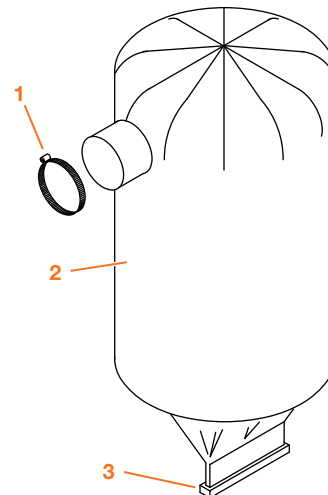



# Parts: Pro-Finish® Blowers (Fans & Motors)

## Blower Assembly Part Numbers

For Dust Collector Models	Horsepower	Part Number	Standard Electrical	CFM at 6" SP	Notes
Dust bag & DCM-80A, SEM-2	1	140311	115/60/1	400	Bag not included
DCM-200, CDC-6 & SEM	1½	140312	230/60/1	600	6" SP at 600 CFM
DCM-200A & CDC-9	2	140313	230/60/1	900	6" SP at 900 CFM
DCM-200B & CDC-12	5	140651	230/50-60/3	1200	10" SP at 1200 CFM

Note: Motor starters, contactors, interconnecting wiring and ducting not included.

## Guide to Component Part Numbers

BLOWER COMPONENTS		PART NUMBERS		
Item	Description	1 HP	1½ HP	2 HP
1 †	Motor, 115-230V, 60 Hz, Single phase	<b>549531</b>	<b>549681</b>	<b>549691</b>
	Motor, 220-480V, 60 Hz, 3 phase	549701	549721	549711
	Motor, 550-600V, 60 Hz, 3 phase	549731	549741	549751
	Motor, 110-220V, 50 Hz, Single phase	549761	549771	549781
Note: Motor part numbers shown in <b>BOLD</b> are supplied as standard most often.				
2	Housing, fan, top	753511	753511	753515
3	Screw, flat head ⅜"-16 x 1"	553271	553271	553271
4	Gasket, fan housing, ⅛" x ¼" (5' section)	523251	523251	523251
5	Screw, flat head ⅜"-16 x 2¼" (dust collector)	553183	553183	553183
6	Gasket, mounting (3 required)	524361	524361	524361
7	Clip, fan guard (4 required)	554431	554431	554431
8	Guard, fan outlet	739011	739011	739025
9	Outlet flange	751501	751501	—
10	Hex nut, ¼"-20	552522	552522	552522
11	Lock washer, ¼"	552752	552752	552752
12	Flat washer, ¼"	552882	552882	552882
13	Housing, fan, bottom	753521	753521	753525
14 †	Impeller (fan blade), 10⅝" dia., ⅝" ID	753021	—	—
	Impeller (fan blade), 11½" dia., ⅝" ID	—	753661	—
	Impeller (fan blade), 12½" dia., ⅝" ID	—	—	753031
15	Bolt, ¼"-20 x 1"	552131	552131	552131

† Essential component to prevent downtime

## Five-Horsepower Blower Assemblies

• Assembly, complete (230-460V, 60 Hz, 3 phase)	PN 549403
• Motor only (230-460V, 60 Hz, 3 phase)	PN 549963
• Impeller only, (old style) 14"	PN 753041
• Impeller only, (current) 16½"	PN 753051

Call for more information.

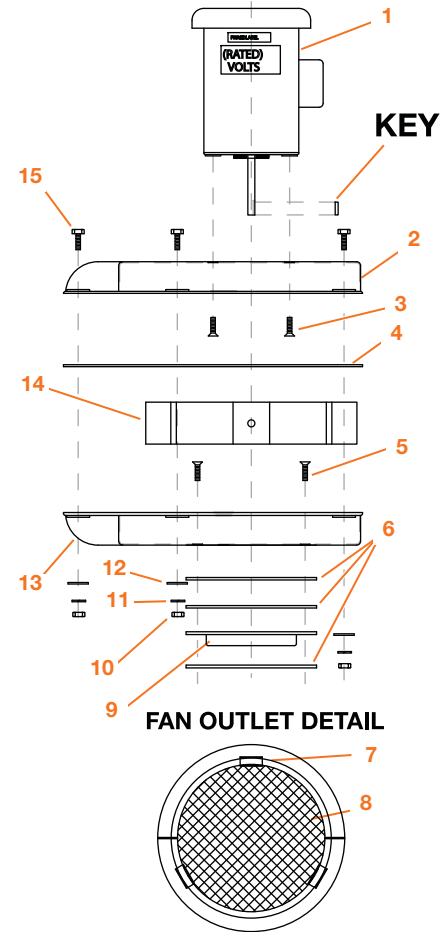



# Parts: Pro-Finish® Ducting, Hoses and Adapters

## Guide to Part Numbers

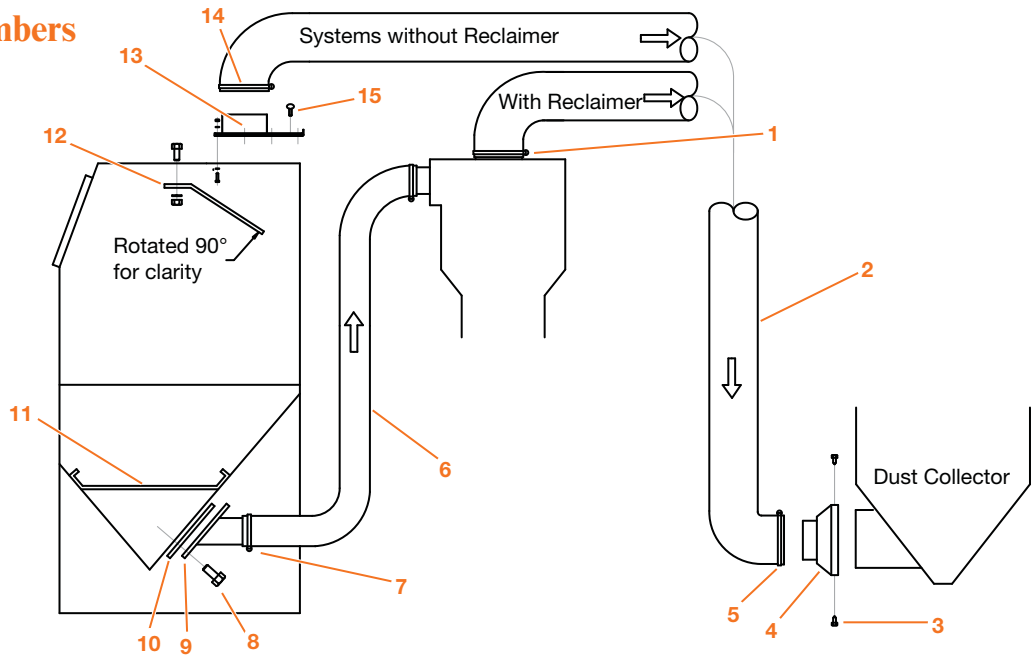

RECLAIMER CAPACITY		400 CFM	600 CFM	900 CFM	1200 CFM
Item	Description	PART NUMBERS			
1	Hose clamp, dust hose (Nominal hose diameter)	520551 (6")	520551 (6")	522314 (10")	522314 (10")
2	Dust hose (I.D. x length)	516101 (6" x 11')	516101 (6" x 11')	516999 (10" x 15')	516999 (10" x 15')
	Dust hose for optional 3.5 ft <sup>3</sup> pressure vessel (I.D. x length)	515631 (6" x 25')	515631 (6" x 25')	516999 (10" x 15')	516999 (10" x 15')
3	Screw, 1/4" - 20 x 1" (3 required)	551560	551560	551560	551560
4	Adapter, dust hose, 6" O.D. x 10 1/8" I.D., DCM-200	NA	761801	NA	NA
5	Hose clamp, dust hose (Nominal hose diameter)	520551 (6")	520551 (6")	522314 (10")	522314 (10")
6	Conveying hose, standard duty, without clamps (I.D. x length)	522351 (4" x 8')	522351 (4" x 8')	516101 (6" x 11')	516101 (6" x 11')
	Conveying hose, heavy duty, with clamps, factory upgrade ** (I.D. x length)	140338 (4" x 9')	140338 (4" x 9')	140339 (6" x 12')	140339 (6" x 12')
	Conveying hose, heavy duty, with clamps, customer install (I.D. x length)	140354 (4" x 9')	140354 (4" x 9')	140355 (6" x 12')	140355 (6" x 12')
	Conveying hose, 4" I.D., heavy duty to length (Specify length)	515911	515911	—	—
	Conveying hose, 6" I.D., heavy duty to length (Specify length)	—	—	515921	515921
	Conveying hose, standard duty, for optional 3.5 ft <sup>3</sup> pressure vessel (I.D. x length)	516033 (4" x 15')	516033 (4" x 15')	516115 (6" x 18')	516115 (6" x 18')
	Conveying hose, heavy duty, for optional 3.5 ft <sup>3</sup> vessel, factory upgrade **	140613	140613	140614	140614
Conveying hose, heavy duty, for optional 3.5 ft <sup>3</sup> vessel, customer install (I.D. x length)	140611 (4" x 18')	140611 (4" x 18')	140612 (6" x 20')	140612 (6" x 20')	
7	Hose clamp, standard duty conveying hose	520531	520531	520551	520551
	Hose clamp, heavy duty conveying hose	522953	522953	522963	522963
8	Bolt, 1/4"-20 x 1" (4 required)	551212	551212	551212	NA
9	Outlet adapter, cabinet	760421	760421	760431	NA
10	Gasket, cabinet outlet	524381	524381	524381	NA
11	Screen (2636 & 3648 cabinets)	766771	766771	766771	766771
	Screen (4848 & 6060 cabinets)	NA	766781	766781	766781

### Suction Systems with a Dust Collector but without a Reclaimer

12	Baffle, ventilation, all size cabinets	760828
13	Slide gate assembly, system with dust bag	760826
	Slide gate assembly, system with collector	760827
14	Clamp for 6" nominal hose	520551
15	Bolt, 1/4"-20 x 1" (5 required)	553554

### Hose Adapters, miscellaneous

10" I.D. x 6" O.D. for DCM 200	761801
6" I.D. x 4" O.D.	764691
6" I.D. x 5" O.D.	509711
5" I.D. x 4" O.D.	511401
6 1/8" I.D. x 5" O.D. with 4 3/4" I.D. fits over 4" HD hose	764032
Block-off plate, outer adapter, seals lower outlet	760451

\* Recommended spare part—Consumable wear item \*\* Not to be ordered as replacement hose.



# Parts: Pro-Finish® Pipe Strings

## Pipe String Assemblies

Description	PART NUMBER
½" pipe string used with one-gun suction	140279
1" pipe string used with pressure & multi-gun suction	140280
1" pipe string used with Ergo-Blast systems	140479

## Pipe String Mounting Hardware

Description	PART NUMBER
¼" flat-head bolt (4 required)	564121
¼" washer (4 required)	552882
¼" hex nut (4 required)	552522

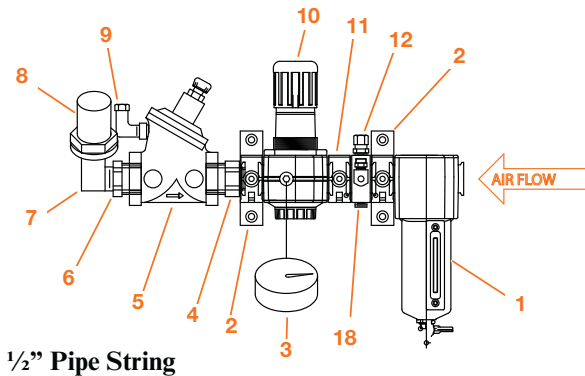

½" Pipe String

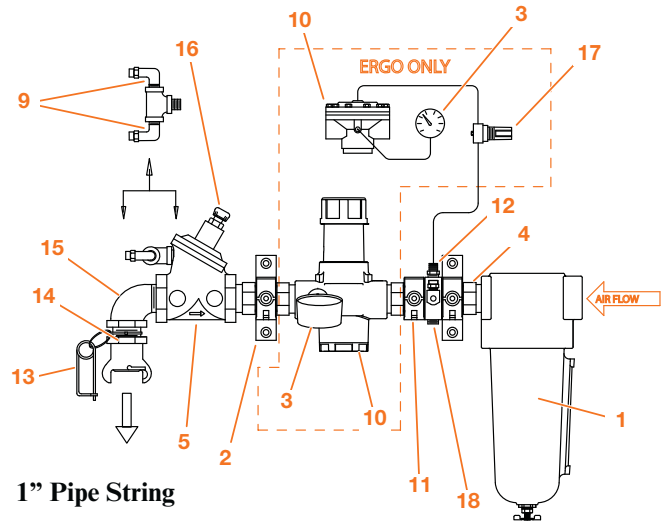

1" Pipe String

## Guide to Part Numbers

PIPE STRING COMPONENTS		PART NUMBERS		
Item	Description	½" String	1" String	Ergo String
1 †	Air filter (½" manual, 1" manual; Norgren)	504652	517271	517271
	Element for Norgren air filter, 5µ	508012	508002	508002
	O-ring and gasket kit for Norgren air filter	508112	505161	505161
2	Mounting feet/quick clamp	522155	522155	522155
3	Gauge, (550232, ¼" NPT; 550212, ⅛" NPT back mount used on Ergo models only)	550232	550232	550212
4	Adapter	522156	522156	522156
5 †	Main air valve (1" Aquamatic)	517042	517042	517042
	Diaphragm and seal kit for 1" Aquamatic	517582	517582	517582
	Special wrench for 1" Aquamatic	518512	518512	518512
	Repair kit for 1" Aquamatic	517583	517583	517583
6	Bushing, 1" x ½" brass	544497	—	—
7	Elbow, ½" x 90°	543533	—	—
8	Hose barb, ½"	520362	—	—
9	Adapter, ¼" tube x ¼" NPT 90°	520432	520432	520432
10 †	Air-pressure regulator (Norgren)	517141	517251	517631
	Diaphragm and O-ring kit for Norgren regulator	508102	508161	508211
11	Quick clamp	522154	522154	522154
12	Hose adapter, ¼" x ¼"	520222	520222	520222
13	Safety pin	—	510511	510511
14	Coupling, 1" FPT, UF-100	—	505782	505782
15	Elbow, 1" NPT street	—	543542	543542
16	Vent	523261	523261	523261
17 †	Regulator, ¼" NPT	—	—	517613
18	Porting block	522157	522157	522157

† Essential component to prevent downtime



# Parts: Pro-Finish® Pressure Blast Systems

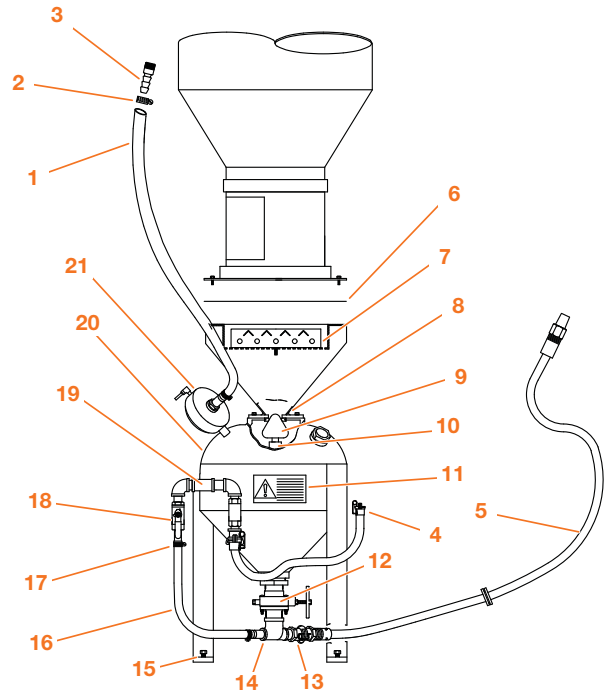

## Exhaust Hose

Item	Description	PART NUMBER
1 *	Exhaust hose with 1" NPT barb ends (5'7" for standard 1 cu. ft. pressure vessel)	522611
	Exhaust hose with 1" NPT barb ends (9' for optional 3.5 cu. ft. vessel)	140691
	Exhaust hose, 1" ID (Max. length: 50')	520822
2 †	Hose clamp, 2" (1 each end)	520512
3 *	Hose barb, 1" NPT x 1" ID hose (1 each end)	520181

## Blast & Air Hoses

Item	Description	Bulk	PART NUMBERS					
			2636	3648 3696	3674	3660	4848	6060 60120
4 †	Air-hose assembly, 1" ID	—	140301	140302	140302	140303	140303	140304
	(Air-hose length)	—	(4')	(5')	(5')	(6')	(6')	(7')
	Air hose, 1" ID	520912	—	—	—	—	—	—
5 *	Blast hose assembly, ½" ID NC/QC (Nozzle adapter not included)	—	522551	522541	521672	521672	521672	522561
	(Blast hose length except Ergo-Blast & FaStrip)	—	(7'6")	(9')	(10')	(10')	(10')	(13')
5 *	Blast hose assembly, ½" ID, Ergo-Blast (Blast hose length for Ergo-Blast models)	—	521672	516271	516271	516271	522561	522561
	Blast hose, ½" ID, maximum length: 50'	520792	—	—	—	—	—	—

## Pressure Vessel

Item	Description	PART NUMBER
6 †	Gasket, reclaimor to hopper	524371
7	Hopper, 1 cubic foot	760741
8 †	Sealing ring, rubber, 2½" ID	523942
9 †	Plunger, sealing, PVC coated	510431
10	Plunger guide, ½" NPT x 3½" nipple	546072
11	Label, WARNING "Do not disassemble . . ."	567332
	Label, WARNING "Flange above . . ."	567312
12	Sure-Flo media regulator, manual (See page A50.)	290383
13	Tank coupling	505782
14	Bullhead tee, 1" x 1" x 2" NPT	545822
15	Leveling bolt, ⅜" - 16 x 3", 1 cu. ft. (3 per assembly)	551902
	Leveling bolt, ½" - 13 x 2¾", 3.5 cu. ft. (3 per assembly)	551982
16	Hose, 1" ID (Specify 1.5' for 1 cu. ft. vessel; 3.5' for 3.5 cu. ft. vessel)	520912
17 †	Hose clamp for 1" ID hose (1 each end)	520581
18	Ball valve, 1" NPT	518492
19	Tee, 1" x 1" x ½" NPT	545702
20	Pressure vessel only, 1 cu. ft.	760811
21	MG-78 exhaust valve (See page A50.)	290182
	Pressure vessel assembly includes items 1 through 3 and 8 through 22.	140300

\* Recommended spare part—Consumable wear item † Essential component to prevent downtime





# Parts: Pro-Finish® Pressure Blast Systems

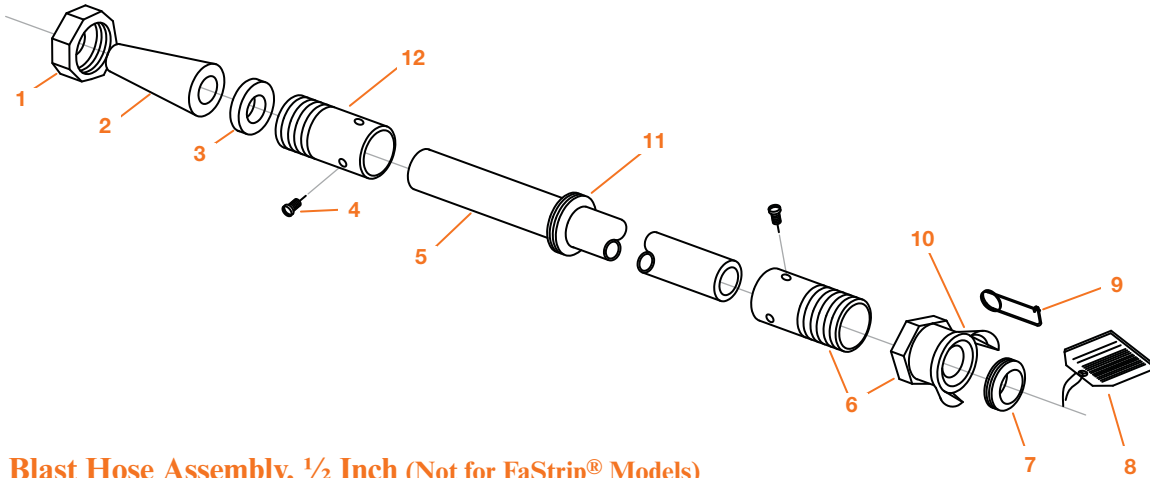

## Blast Hose Assembly, 1/2 Inch (Not for FaStrip® Models)

Item	Description	MODEL NUMBER	PART NUMBER
1 †	Nozzle adapter	NA-2	504912
2	Ceramic nozzle, 3/16" (not included)		502362
3	Nozzle washer, Ceramic nozzle 5/8" ID (10 pack)	NW-5	524041
	Nozzle washer, Di-Carb/Boron, 1/2" ID (10 pack)	NW-2	524052
4 †	Screws (4 pack) Δ	#8 x 3/8"	554242
5	Blast hose, 1/2" ID (specify length)	PBH-1/2	520792
6	Quick coupling with washer and screw package	QC-1/2	505222
7	Coupling washer (10 pack)	AHCW	524101
	Coupling washer (25 pack)	AHCW	525102
8	Tag, safety, screw/coupling	—	564822
9 †	Safety pin Δ	—	510511
10	Tank coupling, 1" FPT with AHCW	UF-100	505782
11	Grommet, blast hose	1" x 1 3/8"	523931
12 †	Nozzle coupling	NC-1/2	505232

ΔWARNINGS: See page A55.

## Pressure Blast Nozzles

Nozzles for pressure blast systems are available in sizes and materials to meet any application requirement.

Size	MODEL AND PART NUMBERS					
	3/32" (#0)	1/8" (#2)	3/16" (#3)	1/4" (#4)	5/16" (#5)	3/8" (#6)
<b>Ceramic (uses NW-5 washer)</b>	CN3-0	CN3-2	CN3-3	CN3-4	CN3-5	CN3-6
Each	502342	502352	502362	502372	502382	502393
Pack of 10	503372	503382	503392	503402	503412	503422
Pack of 50	503432	503422	503452	503462	503472	503482
<b>Di-Carb™ (comes with NW-2 washer)</b>		DC2F-2	DC2F-3	DC2F-4	DC2F-5	
Each		501272	501282	501292	501302	
<b>Boron (comes with NW-2 washer)</b>		NN2F-2	NN2F-3	NN2F-4	NN2F-5	
Each		502022	502032	502042	502052	

• CN3-3 is standard with 1/2" blast hose • CN3-5 supplied with optional 3/4" blast hose. • Consult factory with special requirements.



# Parts: Pro-Finish® Pressure Blast Systems

## Manual Sure-Flo® Media Regulator (Part Number 290383)

Item	Description	PART NUMBER
1	Hex nut, 3/8" - 16 (6 required)	552542
2	Lock washer, 3/8" ID (6 required)	552762
3	Hex bolt, 3/8" - 16 x 3" (2 required)	551902
4	Adapter, manual body, Sure-Flo	753372
5	Handle assembly, 1/2" - 13 x 4"	290384
6	Jam nut, 1/2"	552672
7	Carriage bolt, 3/8" - 16 x 2 1/2" (4 required)	552052
8	Flange, 2" MPT	753292
9 †	Roller stop, holder	753092
10	Screw, 8 - 32 x 1/2" (2 per assembly)	551352
11	Bolt, 7/16" - 14 x 1 1/4"	552222
12 †	Pinch roller (2 per assembly)	753632
13	Valve body, 2" MPT	753692
14 *	Metering tube, 3/4" ID (See below.)	523592

\* Recommended spare part—Consumable wear item

† Essential component to prevent downtime

Note: These fasteners are used two places to mount manual body adapter to Sure-Flo® body.

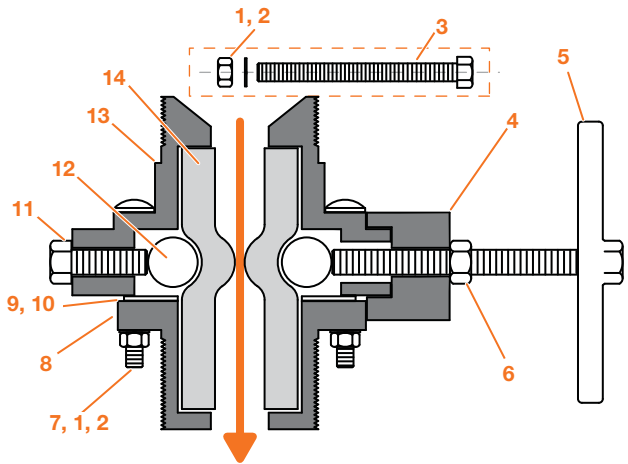

For details on the Automatic Sure-Flo® (PN 290215), see page A73.

Sure-Flo® metering tubes are available in six sizes for work with differing media types and nozzle sizes.

Metering Tube ID	Nozzle Size	Grit Range	Comments	PART NUMBER
3/8"	Small	Fine	Back out roller bolt 1/2"	525451
1/2"	Small-medium	Fine-medium	Back out roller bolt 1/2"	525782
3/4"	Medium-large	Medium	Supplied as standard	523592
3/4"	Medium	Medium	Use below 32° F. (red)	523512
5/8"	Medium	Medium-coarse		525792
7/8"	Large	Coarse	For high-production	525802

## MG-78 Exhaust Valve (Part Number 290182)

Item	Description	PART #
1	Hose barb, 1"	520181
2	Reducer bushing, 1/4" MPT x 1" FPT	544512
3	Valve body	753332
4	Seat, valve ball (steel)	753412
5	Gasket, seat	524132
6	Valve ball	525322
7	Space washer, steel (1/2" ID x 2" OD x 1/4" thick)	553412
8	Spacer ring, outer	753402
9	Bolt, 3/8" - 16 x 2"	553982
	Lock washer, 3/8"	552762
10	Washer (1/2" ID x 2" OD x 1/16" thick)	552842
11	Valve cover	753382
12	Spacer ring, inner	753392
13	Bolt, 1/2" - 13 x 1 3/4"	551962
14	Elbow, brass (1/4" MPT x 1/4" tube)	520242
	Pipe bushing, 1/4" x 1/8"	544302
15	Diaphragm (2 per assembly)	523672
16	Pipe nipple, 1" CLOSE	546192
17	Screws, seat, 1/4" - 20 x 1/2" (pack of 3)	551122

### RESTRICTOR PARTS

18	Nozzle washer, NW-1 (pack of 10)	524062
19	Nozzle washer, NW-4 (pack of 10)	524082
20	Steel washer	552952
	Ceramic restrictor kit (standard)	290218
	Ceramic nozzle (standard)	502431
21	Boron carbide restrictor kit (customer upgrade)	502081
	Boron carbide restrictor kit (factory upgrade)	290184
	Repair kit	290183

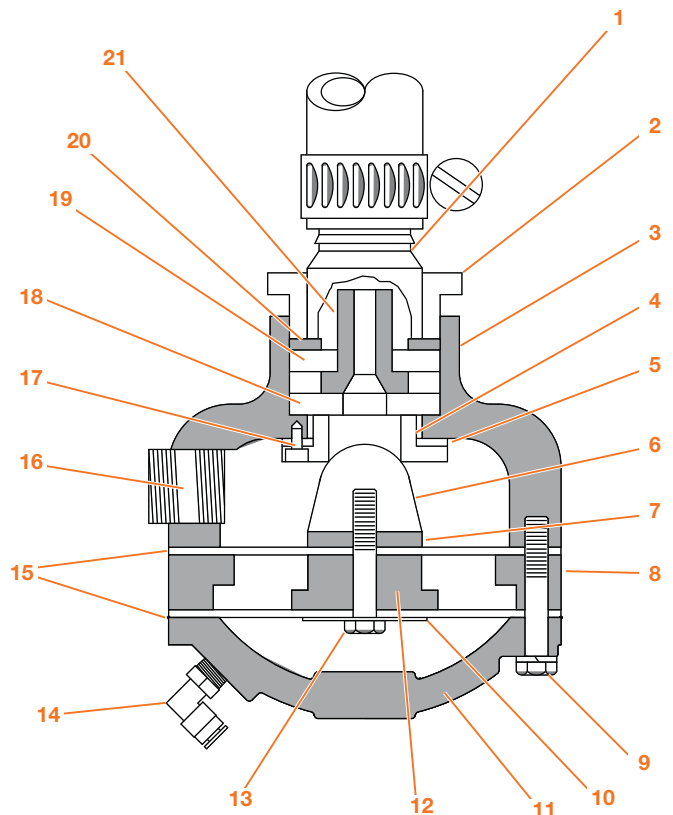



# Parts: Pro-Finish® FaStrip® Blast Systems

FaStrip® blast systems share most of the pressure blast components shown on pages A48 through A50 with other Pro-Finish® pressure models. Many features that are optional with other cabinets are standard with FaStrip®.

## Standard Features with FaStrip®

Item	PART NUMBERS	
	FACTORY INSTALLED	CUSTOMER INSTALLED
1 Automatic Sure-Flo® media regulator (See page A52.)	290215	290215
2 MG-78 CR exhaust valve (See page A53.)	290234	290232
3 Magnetic separator	511572	511572
4 Vibrating reclaimer screen (See page A53.)	140335	140419
5 Blast hose assembly, 3/4" urethane (See below.)	140648	140648

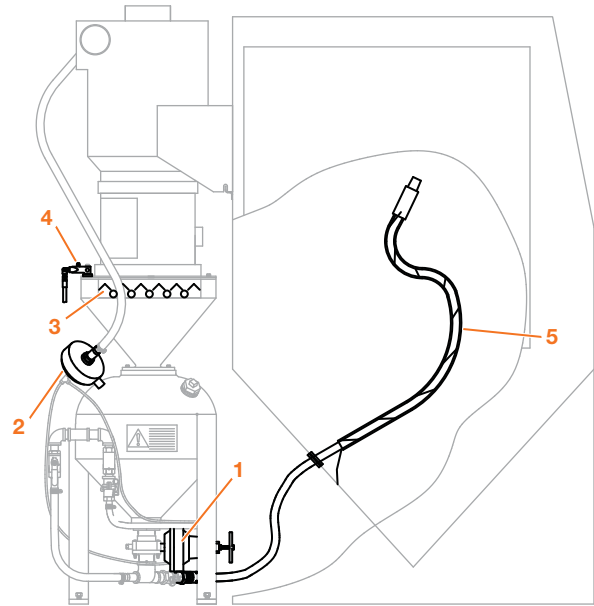

## Blast Hose Assembly, 3/4 Inch Urethane for FaStrip®

Item	Description	PART NUMBER
	3/4" ID blast hose assembly (includes items 1 through 14)	140648
1 *	Silicon carbide nozzle, 3/8"	502742
2 *	Nozzle washers, NW-1, 1" ID x 1 5/8" x 1/4" (pack of 10)	524062
3	Nozzle coupling, 1 1/8" ID for 3/4" hose	754571
4	Grounding wire (specify length)	529813
5	Urethane blast hose, 3/4" (specify length)	523221
6 †	Screws for aluminum & brass couplings, #8 x 5/8" (pack of 4) Δ	554232
7	Outer sheath (after 7/92) (6' required) (specify length)	580171
8	Grommet, blast hose, 1" ID x 1 3/8" OD	523931
	Grommet, blast hose, 1 1/2" x 1 3/4" (10/89 to 7/92)	523331
9	Clamp, adjustable, 1 3/4" ID	520581
10	Nipple, 1/2" NPT x 2 1/2"	546052
11	Coupling, TC-1/2, 1/2" MPT	505212
12 *	Washer, AHCW (pack of 10)	524101
	Washer, AHCW (pack of 25)	525102
13	Tag, safety. screw/coupling Δ	564822
14 †	Safety pin (MUST be used on every quick disconnect) Δ	510511

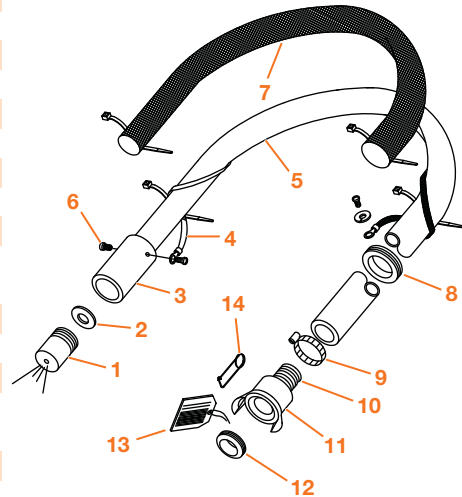

Δ **WARNINGS:** See page A55.

\* Recommended spare part—Consumable wear item

† Essential component to prevent downtime

## Blast Hose Lengths for FaStrip®

	Bulk	2636	3648	3660	3674	4848	6060
Blast hose length for FaStrip models (includes Ergo-Blast models)		12'	12'	13'	13'	13'	15'
Urethane blast hose, 3/4", maximum length: 50' (specify length)	523221	—	—	—	—	—	—

## Blast Nozzles for FaStrip®

SCV-6 is supplied as standard.

Silicon carbide, blue jacket						
Nozzle size	3/16"	1/4"	5/16"	3/8"	7/16"	1/2"
Model	SCV-3	SCV-4	SCV-5	SCV-6	SCV-7	SCV-8
Part Number (each)	502712	502722	502732	502742	502752	502762



# Parts: Pro-Finish® FaStrip® Blast Systems

## Automatic Sure-Flo® Media Regulator Part Number: 290215

Standard with FaStrip® systems. Optional with other Pro-Finish® systems.

Note: These fasteners are used two places to mount diaphragm body to Sure-Flo® valve.

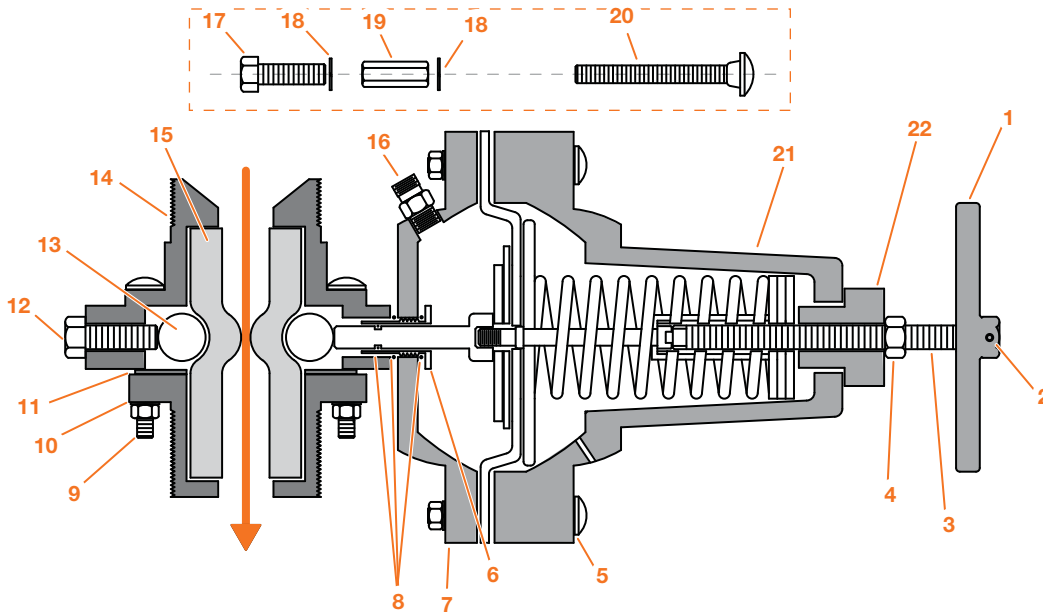

Item	Description	PART #
	Handle assembly, 1/2" - 13, Auto Sure-Flo (after 5/84)	290217
1	Handle assembly, 7/16" - 14 x 4" (before 5/84)	290211
	Handle only, 1/2" - 13	753622
2	Set screw, 1/2" - 13 x 1/2", nyloc	551732
3	Shaft handle	505802
4	Jam nut, 1/2" - 13	552672
	Carriage bolt, 3/8" - 16 x 2 1/2"	552052
5	Lock washer, 3/8" ID	552762
	Hex nut, 3/8" - 16	552542
6	Plunger guide	753462
7	Diaphragm cover	753112
8	O-ring kit (includes 2 for guide, 1 for plunger)	561422
	Carriage bolt, 3/8" - 16 x 2 1/2"	552052
9	Lock washer, 3/8" ID	552762
	Hex nut, 3/8" - 16	552542
10	Flange, 2" MPT	753292
11 †	Roller stop holder	753092
	Screw, 8 - 32 x 1/2" (2 per assembly)	551352
12	Bolt, 7/16" - 14 x 1 1/4"	552222
13 †	Pinch roller (2 per assembly)	753632
14	Valve body, 2" MPT	753692
15 *	Meter tube, 3/4" (See page A50 for choices.)	523592
16	Adapter, 1/4" NPT x 1/4" tube	521081
17	Bolt, 3/8" - 16 x 1 1/4" (2, Auto Sure-Flo)	551852
18	Lock washer, 3/8" ID	552762
19	Nut extension, 3/8" - 16 (2, Auto Sure-Flo)	552662
20	Carriage bolt, 3/8" - 16 x 2 1/2"	552052
21	Spring enclosure	753682
22	Spring tensioner	505822

### Spring & Diaphragm Detail

(Part # 290296 includes items 23 through 28.)

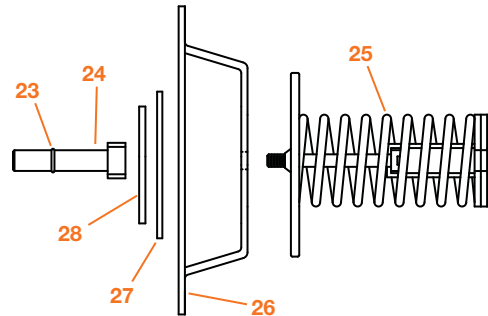

**WARNING: Never attempt to disassemble the spring assembly in the automatic Sure-Flo. The spring is under tension and could cause injury to personnel.**

Item	Description	PART #
23	O-ring kit (includes 2 for guide, 1 for plunger)	561422
24	Plunger with O-ring	505872
25	Spring assembly	290296
26	Diaphragm, raised (after 5/84)	525012
	Diaphragm, flat (before 5/84)	523662
27	Diaphragm gasket	525002
28	Washer, 1/2" ID	552842

\* Recommended spare part—Consumable wear item

† Essential component to prevent downtime



# Parts: Pro-Finish® FaStrip® Blast Systems

## MG-78 CR Exhaust Valve Part Number: 290232

Item	Description	PART #
1	Hose barb, 1"	520181
2	Reducer bushing, 1¼" MPT x 1" FPT	544512
3	Valve body	753332
4	Seat, valve ball (steel)	753412
5	Gasket, seat	524132
6	Valve ball	525322
7	Space washer, steel (½" ID x 2" OD x ¼" thick)	553412
8	Spacer ring, outer	753402
9	Bolt, ⅜" - 16 x 2"	553982
10	Lock washer, ⅜"	552762
11	Washer (½" ID x 2" OD x ⅛" thick)	552842
12	Spacer ring, inner	753392
13	Compression spring	516313
14	Tee, ¼"	545502
15	Elbow, brass, ¼" MPT x ¼" tube (2 required)	520242
16	Nipple, ¼" close	545912
17	Pipe bushing, ½" x ¼"	544462
18	Pipe bushing, ¾" x ½"	544472
19	Bolt, ½" - 13 x 1¾"	551962
20	Valve cover	751801
21	Diaphragm (2 per assembly)	523672
22	Pipe nipple, 1" CLOSE	546192
23	Screws, seat, ¼" - 20 x ½" (pack of 3)	551122
<b>RESTRICTOR PARTS</b>		
23	Nozzle washer, NW-1 (pack of 10)	524062
24	Nozzle washer, NW-4 (pack of 10)	524082
25	Steel washer	552952
	Ceramic restrictor kit (standard)	290218
	Ceramic nozzle (standard)	502431
26	Boron carbide restrictor kit (customer upgrade)	502081
	Boron carbide restrictor kit (factory upgrade)	290184
	Repair kit	290183

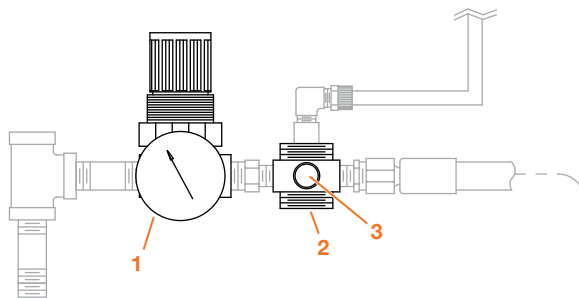
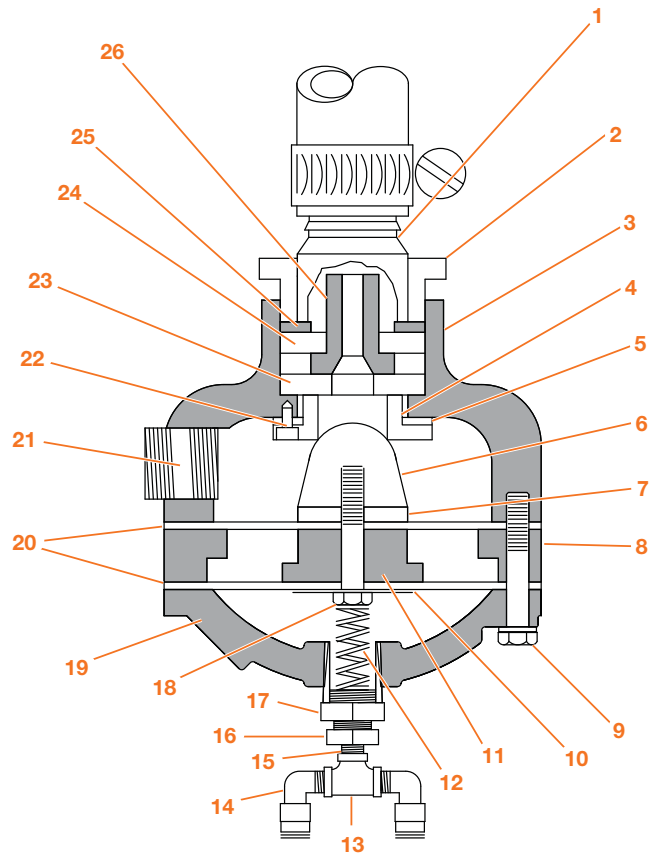

## Vibrating Screen Part Number: 140335

Item	Description	PART #
1	Regulator, relieving	517612
2	Air valve, pilot operated	519011
3	Breather vent	523161
4	Socket-head cap	553601
5	Vibrator	517971
6	Muffler, ⅛" bronze	517281
7	Spacer	536359

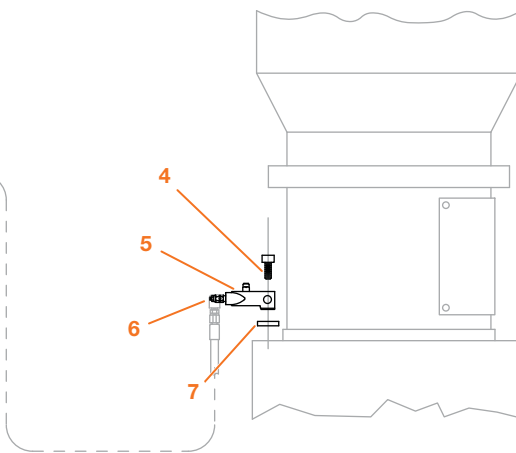



# Parts: Pro-Finish® SafeStrip® Blast Systems

SafeStrip™ blast systems share most of the pressure blast components shown on pages A48 through A50 with other Pro-Finish® pressure models. Differences are highlighted below and on page A54.

## SafeStrip™ System

Item	Description	PART #
1	Dust hose, 8" x 15'	516214
2	Adapter, 10" steel to 8" hose	769914
3	Fine-media reclaimer/defuser assembly	140915
4	Reclaimer/defuser top	760126
5	Conveying hose, 6" x 15'	516213
6	Dust hose, 4"	522923
7	Lid	760123
8	Standard cabinet assembly (See page A38.)	—
9	Foot treadle assembly	140579
10	Hose adapter	760431
11	Blast hose, SafeStrip™ (See page A49.)	521672
11	Blast hose, Single-pass (See page A49.)	521672
12	SafeStrip™ pressure vessel (See below.)	260001
12	Single-pass pressure vessel (See page A54.)	140297

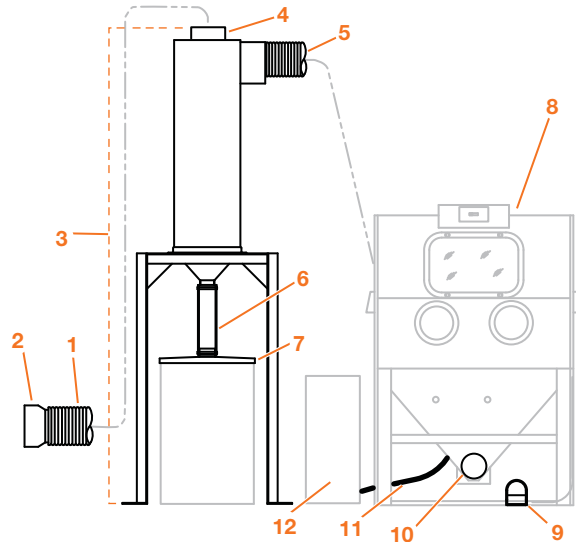

## SafeStrip™ Pressure Vessel (Part Number 260001)

Item	Description	PART #
	Regulator, 2" fixed orifice	340038
1	2" metering disc, 1/8" orifice (factory installed)	754633
	2" metering disc, 3/32" orifice (included)	754643
	2" metering disc, 3/16" orifice (included)	754653
2	Manual air valve, 1" NPT	518492
	Valve, automatic, 1" N.O., S.A.C. bleed	518052
3	Diaphragm/seal kit	517582
	Internal parts kit, bleed	518352
4	Gate valve, 1" bronze non-rising stem	515430
5	Regulator, 1" non relieving	517251
6	Inspection door (not shown)	506152
	Gasket, inspection door (not shown)	524152
7	Differential-pressure gauge	571185
8	Blast-pressure gauge, liquid filled	550391
9	Loading screen	509995
10	Hopper with screen	504325
11	Hopper cover	504326
12	Pin, self locking (2 required per assembly)	510506
13	Sealing plunger (PVC coated), 6"	525072
14	"O" ring, 6" rubber	523872
15	Manual air valve, 1/2" NPT	518472
16	Muffler, 1/2"	506445
17	Check valve, 1" NPT	517503
18	Filter, 1", 5 micron	517271
19	Automatic Sure-Flo® valve assembly	290215
20	Wheel, 10"	505052
21	Tank coupling, (TCB) 1 1/4" NPT, brass	753262
22	Nipple, heavy duty, 1 1/4" x close	546292
23	Nipple, 2" x close	546542
24	Tee, 1 1/4" x 2"	545752

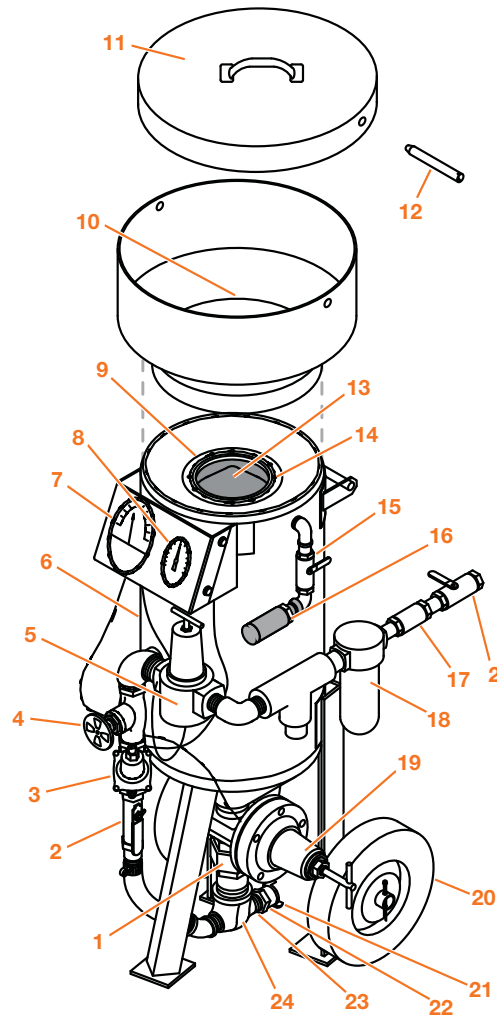



# Parts: Pro-Finish® Single-Pass Blast Systems

Single-pass models use some equipment that differs from that used with standard Pro-Finish® systems. These items are shown on the previous page in the “SafeStrip™ System” drawing and on this page in the “Single-Pass Pressure Vessel” drawing.

## Single-Pass Pressure Vessel

(Part Number 140297 includes items 3 through 13)

Item	Description	PART #
1	Hopper with lid	767363
	Screen (not shown)	767572
2	Gasket	524371
3	Sure-Flo® media regulator, manual (See page A50.)	290383
4	Nipple, 1" NPT x close, HD	546192
5	Tee, 1" x 1" x 1/2" NPT	545822
6	Leveling bolt, 3/8" - 16 x 2", 1 ft <sup>3</sup> (3 per assembly)	551742
	Leveling bolt, 1/2" - 13 x 2 3/4", 3.5 ft <sup>3</sup> (3 per assembly)	551982
7	Hose, 1" ID (Specify 1.5' for 1 ft <sup>3</sup> vessel)	520912
	Hose, 1" ID (Specify 3.5' for 1 ft <sup>3</sup> vessel)	520912
8 †	Hose clamp for 1" ID hose (1 each end)	520581
9	Ball valve, 1" NPT	518492
10	Tee, 1" x 1" x 1/2" NPT	545702
11	Pressure vessel only, 1 ft <sup>3</sup>	760811
12	MG-78 exhaust valve (See page A50.)	290182

† Essential component to prevent downtime

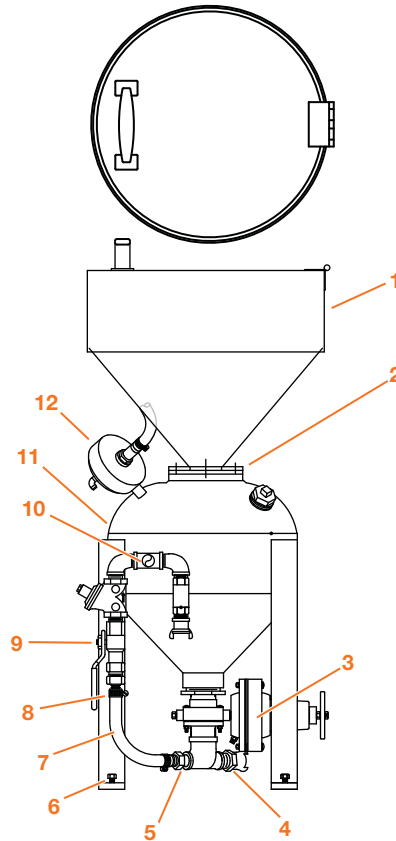

## ⚠ WARNINGS—Pressure Blast Systems

### ALL SYSTEMS

- EMPIRE will not warrant equipment or assume responsibility for damage or injury resulting from neglect or use of improper parts. Failure to follow procedures, which could cause injury and death, constitutes misuse of the product.
- Do not exceed 125 psi inlet pressure.
- Do not disassemble when pressurized or with air supply connected. Be sure all fastenings, including sight plugs, are tightened properly.

### PRESSURE VESSEL

- Flange above pop-up valve must be secured before vessel is pressurized.
- Never drill, weld or otherwise alter the pressure vessel. If modifications are required, contact EMPIRE or an A.S.M.E. certified welding shop.

### COUPLINGS

- Inspect couplings and blast hose daily for splits, bubbles, soft spots, wear, etc. Make sure nozzle washers are in good condition and screw heads are snug against coupling surfaces. The safety pin (PN 510511) must be in place to prevent disconnection of quick couplings.
- When assembling couplings to blast hose use only #8 x 5/8" long, self-tapping, sheet-metal screws (PN 554232) for cast brass and aluminum couplings and #8 x 3/8" long, self-tapping, sheet-metal screws (PN 554242) for all steel couplings. Use of other types of screws may create a safety hazard.

### AUTOMATIC SURE-FLO® MEDIA REGULATOR

- Never attempt to disassemble the spring assembly in the automatic Sure-Flo® media regulator. The spring is under high compression and may injure personnel.

**Never use silica sand in any Empire equipment.**



# Parts: Pro-Finish® Suction Blast Systems

## Guide to Part Numbers

### Hopper Assembly

Item	Description	PART NUMBER
1	Grommet, air hose, 3/4" x 1 1/16"	523921
2	Grommet, blast hose, 1" x 1 3/8"	523931
3	Gasket, cabinet outlet	524381
4	Outlet adapter, cabinet, 1 1/4" NPT for SAR-2 (no reclaimer)	760441
5	SAR-2 media regulator, complete, 1 1/4" FPT	290156
5a	SAR-2 media regulator, body	753351
5b	Thumb screw, 1/4" - 20 x 1"	551042
5c	Plug, clean out	510121
6	Hopper, 1 gun suction	760751
7 †	Gasket, reclaimer to hopper	524371
8	Pipe nipple, 1 1/4" x 5"	546742
9	Hose clamp, 1/2" air hose (2 per hose)	520502

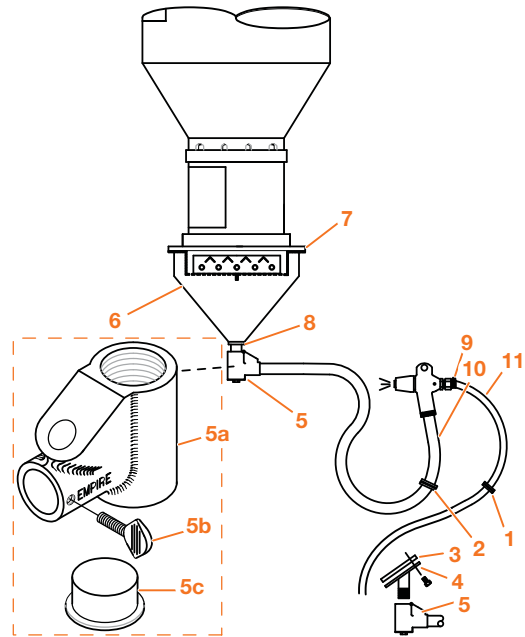

### Blast & Air Hoses

Item	Description	Bulk	PART NUMBERS					
			2636	3648 3696	3674	3660	4848	6060 60120
10 *	Blast hose section, 5/8" ID (Blast hose length)	—	522571 (7')	522581 (8')	522591 (9')	522591 (9')	522591 (9')	522601 (13')
	Blast hose section, 5/8" ID, Ergo-Blast (Blast hose length for Ergo-Blast models)	—	522591 (9')	522601 (12')	522601 (12')	522601 (12')	522601 (12')	522601 (13')
	Blast hose, 5/8" ID, maximum length: 50'	520802	—	—	—	—	—	—
11 †	Air-hose assembly, 1/2" ID (Air-hose length)	—	522831 (7.5')	522841 (7')	522851 (8')	522851 (8')	522851 (8')	522861 (10')
	Air-hose assembly, 1/2" ID, Ergo-Blast (Air-hose length for Ergo-Blast models)	—	522861 (10')	522861 (10')	522861 (10')	522861 (10')	516261 (10')	522861 (10')
	Air hose, 1/2" ID, maximum length: 50'	520861	—	—	—	—	—	—

\* Recommended spare part—Consumable wear item

† Essential component to prevent downtime





# Parts: Pro-Finish® Suction Blast Systems

## MH-2 Guns

Item	Description	PART NUMBER
1 *	Gun body, MH-2 long handle	735551
2 *	Ceramic nozzle, 5/16" (standard)	502431
3 *	Air jet, 5/32" (green)	505671
4 *	Nozzle adapter, plastic	505641
5	Spring, suction-gun assist	511251
6	Nut, hose clamp, MH-2	520081
7	O-ring 1 1/16" ID x 1 5/16" OD	523881
8	Screw set, 1/4" - 20 x 3/8"	551052
9	Connector, MH-2	505631
10	Hose barb, 1/2" FPT x 1/2" hose	520402
11	O-ring, 1/2" ID x 5/8" OD (2 required)	523912

\* Recommended spare part—Consumable wear item

† Essential component to prevent downtime

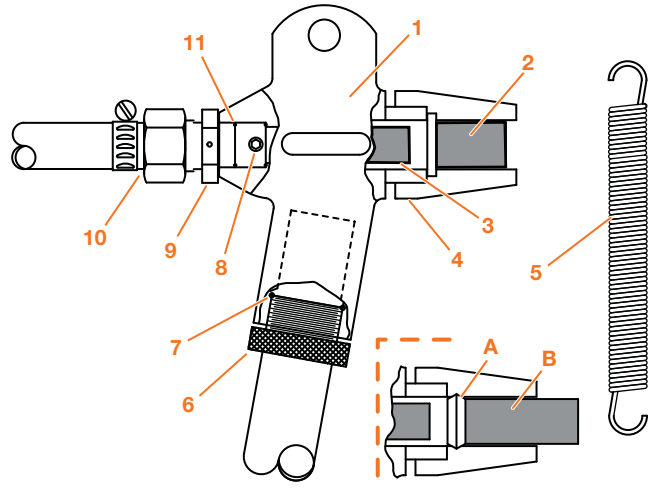

### Optional for Wide-Spray Setup

Item	Description	PART NUMBER
A *	Compression ring	752453
B *	Di-Carb™ nozzle, 3/8" wide spray	503573
	Boron nozzle, 3/8" wide spray	503563

\* Recommended spare part—Consumable wear item

## MH-2 Suction Gun Assemblies

Nozzle (Air Jet) Diameters	PART NUMBERS			PART NUMBERS		
	Long-Handle Gun with			Short-Handle Gun with		
	1/4" (1/8")	5/16" (5/32")	7/16" (7/32")	1/4" (1/8")	5/16" (5/32")	7/16" (7/32")
<b>Ceramic nozzle</b>	505521	505481	505491	505531	505541	505551
<b>Di-Carb™ nozzle</b>	505501	505441	505451	505561	505571	505581
<b>Boron nozzle</b>	505511	505461	505471	505591	505601	505611

• Long-handle gun with 5/16" ceramic nozzle (505481) supplied as standard.

### Nozzles for MH-2 Guns

Diameter (#)	1/4" (#4)	5/16" (#5)	7/16" (#7)
	PART NUMBERS		
Ceramic (each)	502421	502431	502441
Ceramic (10 pack)	503341	503351	503361
Di-Carb™ (each)	501331	501341	501351
Boron (each)	502071	502081	502091

### Air Jets for MH-2 Guns

Diameter	Designation	Note	PART NUMBER
3/32"	orange		505651
1/8"	yellow		505661
5/32"	green	Standard	505671
3/16"	blue		505681
7/32"	white		505691
1/4"	red		505701





# Options Details: Pro-Finish® Cabinets

## Cabinet Options (For Pressure or Suction Systems)

PART NUMBERS  
FACTORY INSTALLED CUSTOMER INSTALLED

<b>Antistatic strap</b> prevents static shock to the operator.	510411	510411
<b>Armrest assembly</b> reduces fatigue. (included with Ergo-Blast models)		
2636 cabinets only	140595	140595
Other cabinets	140596	140596
<b>Door locking clamps</b> prevent unauthorized release of particulates when swing doors are opened.		
Right-door clamp with timer	140628	140630
Right-door clamp without timer	140624	140626
Clamps for two doors with timer	140629	140631
Clamps for two doors without timer	140625	140627
<b>Door mounted basket assembly</b> automates batch processing of small parts.		
Assembly with uncoated basket	140342	140406
Assembly with PVC-coated basket	140404	140405

### Door Basket Components

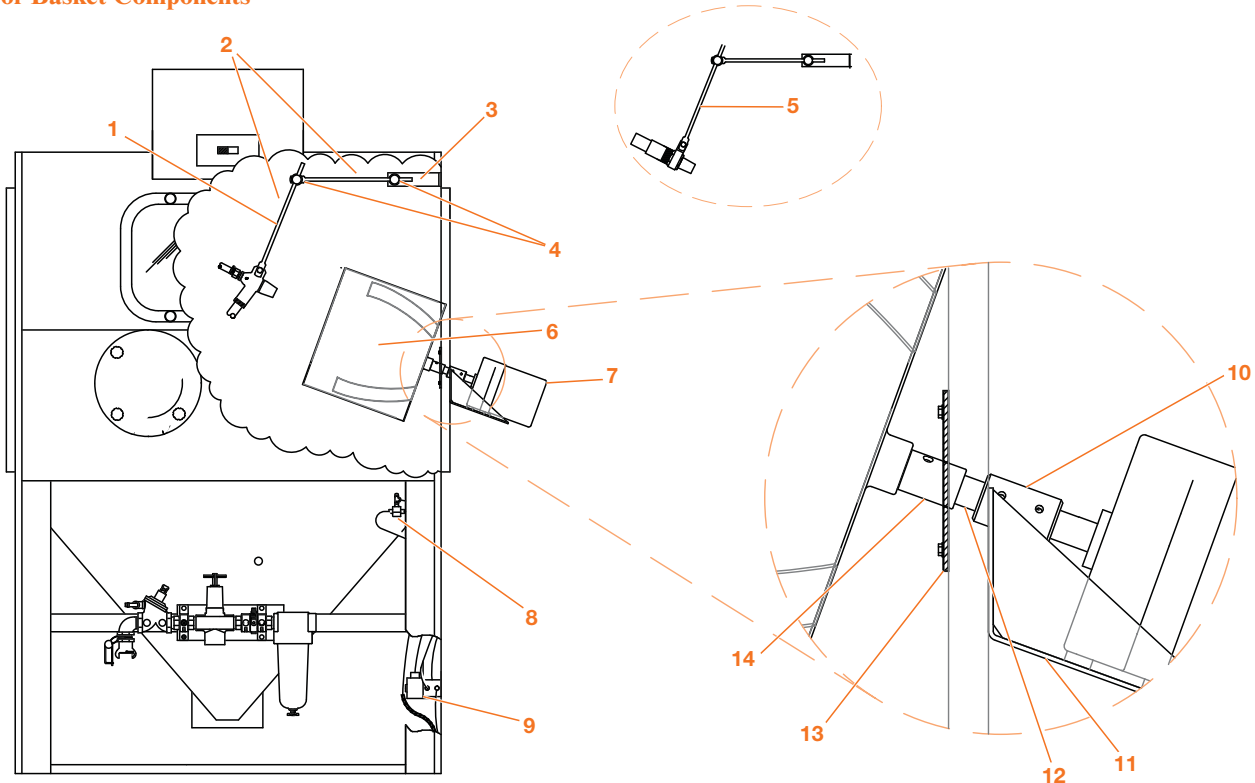

Item	Description	PART #	Item	Description	PART #
1	Gun holder assembly, suction (Includes 2, 3, 4)	140400	8	Shuttle valve, 1/8" NPT	518011
2	Extension arm	510731	9	Solenoid valve	518591
3	Mounting bracket	509541	10	Shaft coupling	570211
4	Knuckle assembly	560231	11	Gear motor bracket	510311
5	Nozzle holder assembly, pressure	140401	12	Shaft	510741
	Nozzle holder pressure, end arm only	509211	13	Shaft seal	523771
6	Basket, 12" x 14", uncoated	510381	14	Basket socket	753751
	Basket, 12" x 14", PVC coated	510911		Electric timer, 0 to 60 minutes (not shown)	531041
7	Motor, 1/4 HP, 115 V/60 Hz/1 ph (6 RPM)	549621			

<b>Glove hole plugs</b> seal cabinet for automated operation.	140623	140622
<b>HEPA inlet filter</b> captures very fine particles. (Cannot be used with sound damper/PN 140597.)	140190	140190
<b>Filter replacement</b>	516303	516303
<b>Magnetic separator</b> extracts ferrous debris during the media-reclamation process.	511572	511572



# Options Details: Pro-Finish® Cabinets

## Cabinet Options (continued)

PART NUMBERS  
**FACTORY INSTALLED**    **CUSTOMER INSTALLED**

Oscillator assemblies automate nozzle/gun movement.

140424    140402

### Oscillator Components

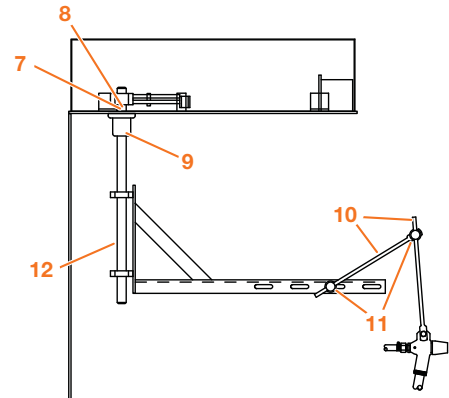
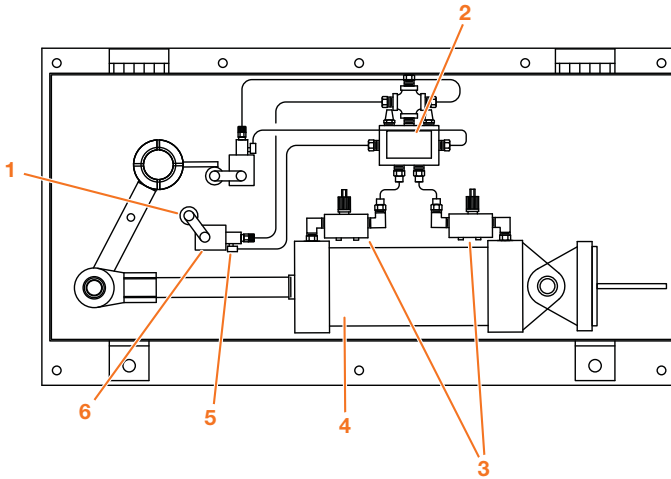

Item	Description	PART #
1	Cam roller	509261
2	Air valve, 1/8" NPT	518581
3	Flow control valve, 1/4" NPT	517743
4	Air cylinder	509221
5	Air valve, 1/8" NPT	517221
6	Cam operator	509251

Item	Description	PART #
9	Flange bearing	570141
10	Extension arm	510731
11	Knuckle assembly	560231
	Suction fixed gun holder assembly (includes 9, 10 & 11)	140400
	Pressure nozzle holder assembly (not shown)	140401
12	Shaft	761871

Rubber curtains shield cabinet interior from harsh abrasives, prolong equipment life.

(Part numbers shown below)

Cabinet Size	FACTORY INSTALLED			CUSTOMER INSTALLED		
	BLACK CURTAINS Cone	BLACK CURTAINS Front Wall	BLACK CURTAINS Side & Back Walls	WHITE CURTAINS Cone	WHITE CURTAINS Front Wall	WHITE CURTAINS Side & Back Walls
2636	510751	140642	510791	140550	140767	140554
3648	510761	140640	510801	140551	140577	140555
3660	140826	140827	140828	140829	140830	140831
3674	140693	140694	140692	140886	140967	140888
3696†	510761	140640	510801	140551	140577	140555
4848	510771	140640	510811	140552	140577	140556
6060	510781	140638	510921	140553	140977	140557
60120†	510781	140638	510921	140553	140977	140557

\* Ergo-Blast models require different curtain size. Call factory.

† Twin cabinets: two items required for upgrade of both cabinets

• Attaching these neoprene curtains requires 1/4-20 studs, brass grommets and rubber nuts (PN 523533).



# Options Details: Pro-Finish® Cabinets

## Cabinet Options (continued)

**PART NUMBERS**  
**FACTORY INSTALLED**    **CUSTOMER INSTALLED**

**Safety matting** protects turntables, cabinet floors and workers. (Two-foot-wide safety matting, with pockets to catch spilled media, is sold by the linear foot. Lengths required are shown below. Specify total length required when ordering.)

509002                      509002

**18" Turntable Covering:** 2 feet    **24" Turntable Covering:** 2 feet    **36" Turntable Covering:** 4 feet    **48" Turntable Covering:** 8 feet  
*Lengths required for each cabinet size*

	<b>2636</b>	<b>3648</b>	<b>3660</b>	<b>3674</b>	<b>3696</b>	<b>4848</b>	<b>6060</b>	<b>60120</b>
<b>Floor inside cabinet</b>	3 feet	6 feet	8 feet	10 feet	12 feet	8 feet	13 feet	25 feet
<b>Shop floor outside:</b>								
<b>cabinet</b>	11 feet	14 feet	15 feet	16 feet	18 feet	16 feet	19 feet	24 feet
<b>with rolling turntable on dolly</b>	14 feet	16 feet	18 feet	20 feet	20 feet	24 feet	27 feet	32 feet

**PART NUMBERS**  
**FACTORY INSTALLED**    **CUSTOMER INSTALLED**

**System-security key lock** prevents unauthorized use of the cabinet.

140864                      140864

**Timer**, electronic, features ease of operation and precise control of on/off intervals. For part replacement information, call factory.

140536                      140535

**Timer**, mechanical, can be set for intervals of up to 60 minutes. For part replacement information, call factory.

140420                      140421

**Turntables** facilitate the processing of heavy parts and provide opportunities to automate. See page A61 and A62 for component part numbers of turntable assemblies.

(Part numbers shown below)

### Turntables

*Part Numbers shown in this table are Factory Installed with some field assembly required.*

	<b>MANUAL ROTATION TURNTABLES</b>								<b>POWERED ROTATION TURNTABLES</b>			
	<b>STATIONARY</b>				<b>ROLLING</b>				<b>STATIONARY</b>		<b>ROLLING</b>	
	<b>Diameter</b>	<b>18"</b>	<b>18"</b>	<b>24"</b>	<b>36"</b>	<b>18"</b>	<b>24"</b>	<b>36"</b>	<b>24"</b>	<b>36"</b>	<b>24"</b>	<b>36"</b>
<b>Profile</b>	<b>Std.</b>	<b>Low</b>	<b>Low</b>	<b>Low</b>	<b>Std.</b>	<b>Std.</b>	<b>Std.</b>	<b>Low</b>	<b>Low</b>	<b>Std.</b>	<b>Std.</b>	
<b>Capacity</b>	<b>300#</b>	<b>300#</b>	<b>300#</b>	<b>300#</b>	<b>1000#</b>	<b>1000#</b>	<b>1000#</b>	<b>300#</b>	<b>300#</b>	<b>1000#</b>	<b>1000#</b>	
<b>2636</b>	140422	140574	140502	NA	140321	NA	NA	NA	NA	NA	NA	
<b>3648</b>	140422	140574	140502	NA	NA	140322	NA	140504*	NA	140364	NA	
<b>3660</b>	140422	140574	140502	NA	NA	140324	NA	140504*	NA	140375	NA	
<b>3674</b>	140422	140574	140502	NA	NA	140322	NA	140504	NA	140364	NA	
<b>3696†</b>	140422	140574	140502	NA	NA	140322	NA	140504*	NA	NA	NA	
<b>4848</b>	140422	140574	140502	140503	NA	140322	140323	140504*	140505*	140364	140365	
<b>6060</b>	140422	140574	140502	140503	NA	140324	140325	140504*	140505*	140375	140376	
<b>60120†</b>	140422	140574	140502	140503	NA	140324	140425	140504	140505	NA	NA	

\* Not available on Ergo-Blast models.

† Two required for both cabinet stations.

• Powered turntables require a maximum of 30 SCFM compressed air.

• Part numbers may be used to retrofit existing systems. Customer installation of low-profile turntables requires cutting, fitting and welding.

**Never use silica sand in any Empire equipment.**



# Options Details: Pro-Finish® Cabinets

## Turntables

### Powered Turntables

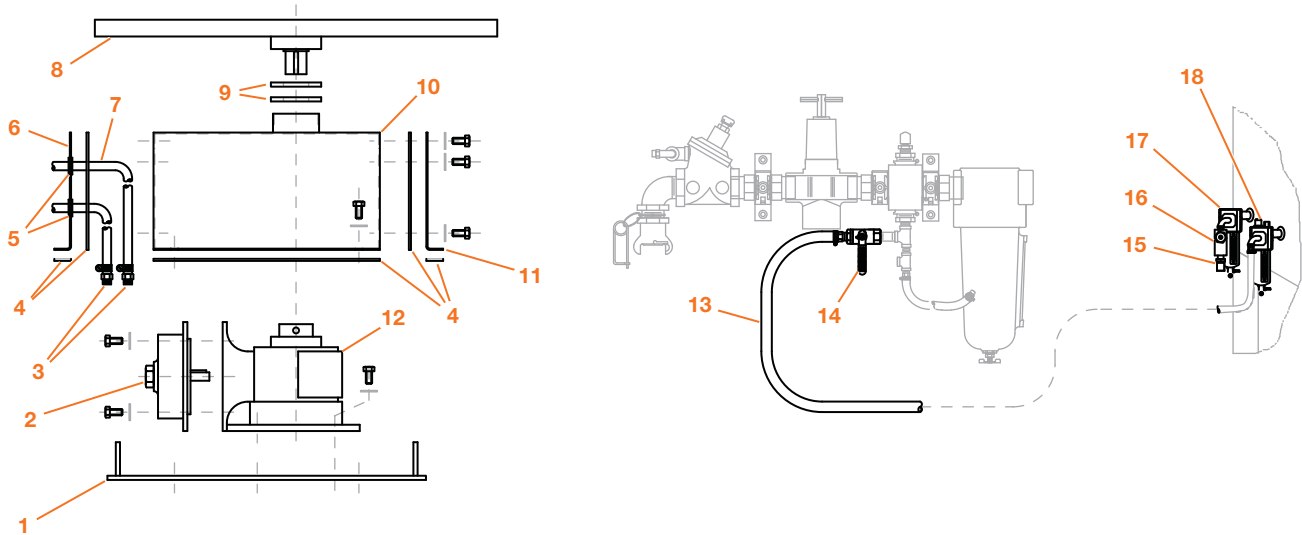

Item	Description	PART #	Item	Description	PART #
1	Mounting plate	768701		Air-hose assembly	
	Air motor	549891		(3648, 1/4" x 6' long)	140861
2	Repair kit, Gast motor	549871	13	(3674, 1/4" x 6' long)	140861
	Repair kit, Fenner-Stone motor	549881		(3660, 1/4" x 6' long)	140861
3	Hose barb, 3/8" NPT to 1/2" hose	520372		(4848, 1/4" x 7' long)	140862
4	Gasket, 1/8" x 1/4" x 5' long	523571		(6060, 1/4" x 8' long)	140863
5	Grommet, 3/4" ID x 1 3/8" (quantity 4)	523921	14	Ball valve, 1/2"	518472
6	End plate, left side	768681	15	Muffler, 1/2" NPT	506443
7	Air hose, 1/2" ID (Specify length.)	520861	16	Flow-control valve, 1/2"	517751
8	24" turntable top	768561	17	Oil-vapor-removal filter, 1/2"	511621
	36" turntable top	768571	18	Lubricator, 1/2"	511631
9	Seal (2 required)	516001			
10	Cover	768641			
11	End plate, right side	768671			
12	Gear reducer	549801			



# Options Details: Pro-Finish® Cabinets

## Turntables

### Table, Cart & Wheels

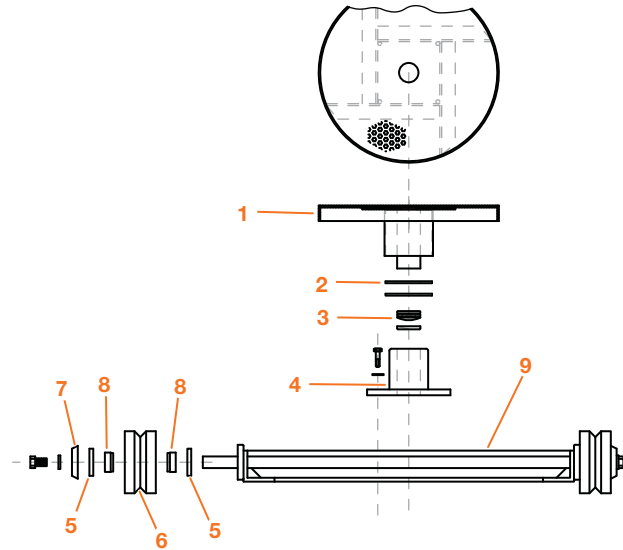

Item	Description	PART #
1	18" turntable	768581
	24" turntable	768591
	36" turntable	768601
	48" turntable	768648
2	Seal (5 required)	516001
3	Bearing thrust	570091
4	Bearing	570141
5	Wheel-bearing seals (2 required per wheel)	
	Inner seal, 2 3/16" OD	525971
	Outer seal, 1 3/4" OD	580351
6	V-groove wheel	509841
7	Outside cup	600291
8	Cotter pin 3/16" x 1 1/4" (before 1987)	553002
	Hub insert	767071
9	Cart & wheels assembly, 2636 only	140508
	3648, 3660, 4848, 3674 & 6060	140501

### Tracks & Platforms

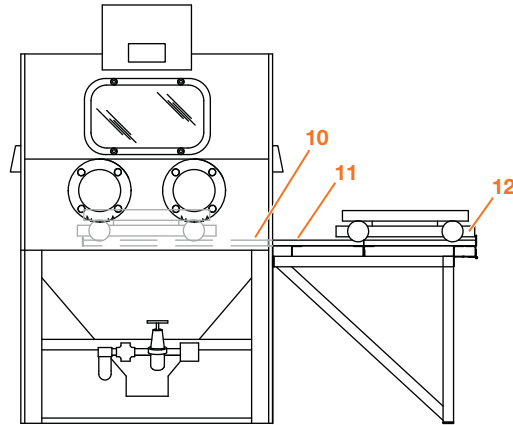

Item	Description	PART #
10	Inside track for: 2636, 1 door	760991
	For: 3648, 3660, 3674, 3696 & 4848, 1 door	761001
	For: 6060 & 60120, 1 door	761021
	For: 3648, 3660, 3674 & 4848, 2 doors	766721
	For: 6060, 2 doors)	766731
11	Outside track for: 2636	760951
	3648, 3660, 3674, 3696, 4848, 6060 & 60120	760961
12	Manual turntable with 18" dolly	140456
	Manual turntable with 24" dolly	140457
	Manual turntable with 36" dolly	140458
	Manual turntable with 48" dolly	140448



# Options Details: Pro-Finish® Cabinets

## Vertical Doors

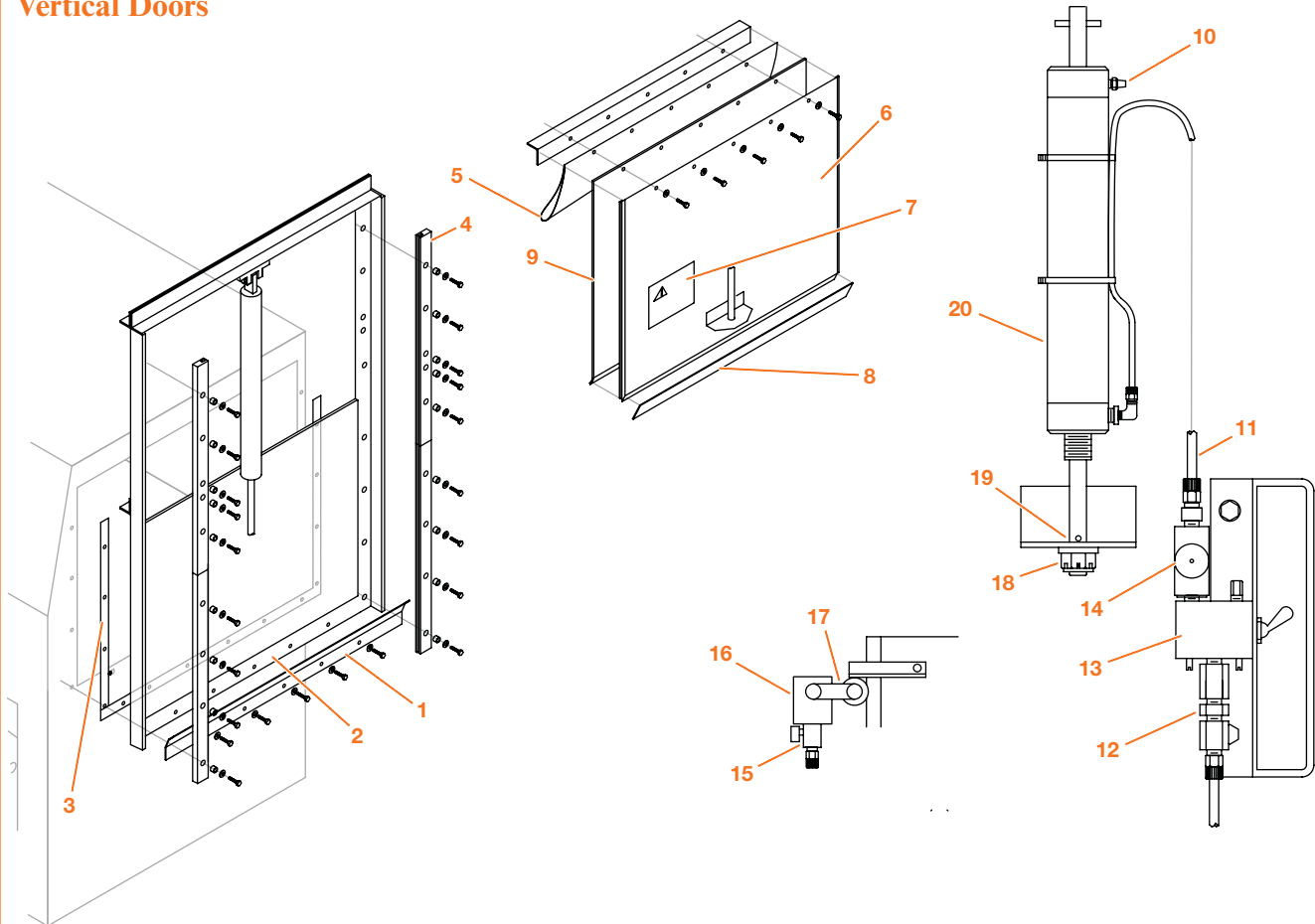

Parts for Vertical Doors		CABINET SIZE					
		2636	3648 3696	3660	3674	4848	6060 60120
Item	Description	PART NUMBERS					
	Vertical door assembly, complete	140491	140490	140490	140490	140489	140488
1	Lower gate	767401	767391	767391	767391	767381	767371
2	Lower gasket	526051	526041	526041	526041	526031	526021
3	Side gasket (4 required for 6060, 2 for others)	526011	526001	526001	526001	525991	525981
4	Track-guide assembly, 2 piece	767344	767340	767340	767340	767340	767340
5	Seal, vertical door	525636	525648	525648	525648	525848	525060
6	Panel, vertical door	767281	767271	767271	767271	767261	767251
7	Caution label	567221	567221	567221	567221	567221	567221
8	Seal, bottom door	526301	526311	526311	526311	526321	526331
9	Gasket, vertical door	526091	526081	526081	526081	526071	526061
10	Muffler	505722	505722	505722	505722	505722	505722
11 *	Polyester tubing (Specify length)	510541	510541	510541	510541	510541	510541
12 *	Check valve, 1/4"	517572	517572	517572	517572	517572	517572
13	Air-control valve, 1/8"	518031	518031	518031	518031	518031	518031
14	Flow-control valve, 1/8"	517721	517721	517721	517721	517721	517721
15	Push button valve	517221	517221	517221	517221	517221	517221
16	Cam operator	509251	509251	509251	509251	509251	509251
17	Cam roller	509261	509261	509261	509261	509261	509261
18	Castle nut	554581	554581	554581	554581	554581	554581
19	Roll pin	554291	554291	554291	554291	554291	554291
20	Air cylinder	518621	518863	518863	518863	518863	518873
	Orifice, .062" (not shown)	755281	755281	755281	755281	755281	755281

\* Recommended spare part



# Options Details: Pro-Finish® Cabinets

## Cabinet Options (continued)

PART NUMBERS	
FACTORY INSTALLED	CUSTOMER INSTALLED

**Vibrating screen** assures smooth flow of light and fine media. (Included with FaStrip® models.)

140335

140419

### Vibrating Screen Components

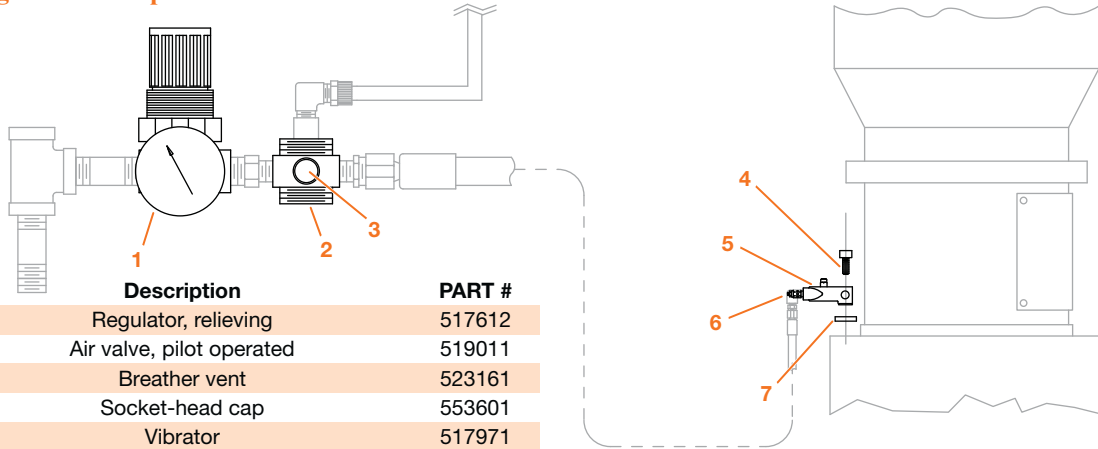

Item	Description	PART #
1	Regulator, relieving	517612
2	Air valve, pilot operated	519011
3	Breather vent	523161
4	Socket-head cap	553601
5	Vibrator	517971
6	Muffler, 1/8" bronze	517281
7	Spacer	536359

**Window protector**, made of clear plastic, is recommended for use with light, less aggressive abrasives.

509191

509191

**Window protector**, consisting of a steel screen, protects against heavy and coarse media.

509201

509201



Never use silica sand in any Empire equipment.





# Options Details: Pro-Finish® Dust Collectors

## Bag House Dust Collector Options

For DCM-80A (PN 112000), DCR-80 (PN 112100), DCM-200 (PN 113000), DCM-200A (PN 113001) & DCM-200B (PN 113002)

PART NUMBERS	
FACTORY INSTALLED	CUSTOMER INSTALLED

**Bag shaker, automatic electric**, cleans bags thoroughly every time the system is turned off.

140340

140390

For DCM-80A, DCR-80, DCM-200, DCM-200A & DCM-200B

### Bag Shaker, Automatic Electric Components

Item	Description	PART #
1	Pressure switch, differential	550311
2	Timer	531081
3	Flasher	535313
4	Solenoid valve, 120 VAC	517311
5	Cylinder (not included; standard with collector)	515981

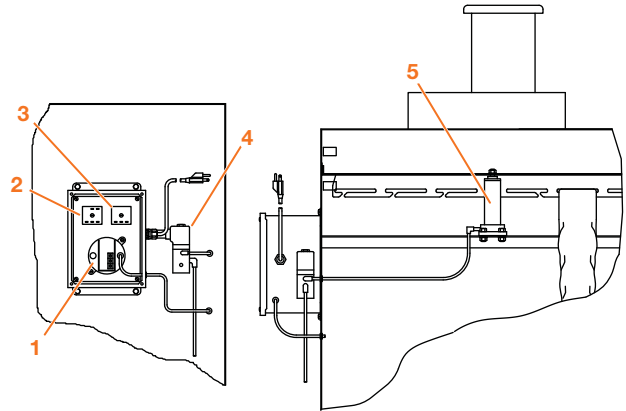

**Bag shaker, automatic pneumatic** for DCM-80A

140685

140686

For part information: **Call factory.**

**Bag shaker, automatic pneumatic** for DCM-200, DCM-200A & DCM-200B

140683

140684

For part information: **Call factory.**

**HEPA filter** captures very fine particles.

140215

140215

**Replacement filter**

516305

516305

**HEPA filter, pressure differential gauge assembly** informs operator regarding filter cleanliness.

140221

140221

**Leg extension kit** raises collector so larger collection drum can be placed underneath.

**Kit for DCM-80A**

140170

140170

**Kit for DCM-200, DCM-200A & DCM-200B**

140180

140180

**Lid assembly** for 55 gallon drum attaches securely to clean-out door.

140255

140255

### Lid Assembly Components

Item	Description	PART #
1	Hose clamp, 4"	520531
2	Dust hose, light-duty, 4"	522923
3	Hose clamp, 4"	520531
4	Adapter	760412
5	Lid, 55 gallon drum	761007
	Gasket for lid, 7' (not shown)	800166

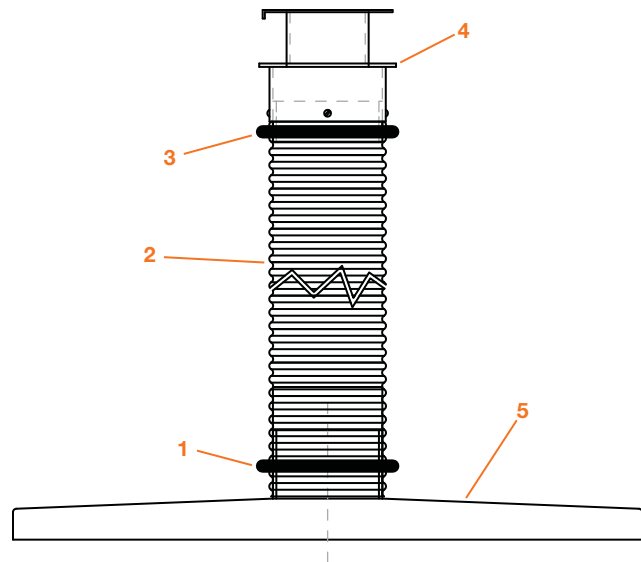

**Manometer** keeps operator informed regarding bag cleanliness.

140344

140398

**Sound attenuator/exhaust damper** reduces noise in the work place.

**Attenuator/damper** for DCM-80A & DCM-200

140361

140361

**Attenuator/damper** for DCM-200A

140769

140769

**Attenuator/damper** for DCM-200B

140680

140680



# Options Details: Pro-Finish® Dust Collectors

## Cartridge Dust Collector Options

For CDC-6 (PN 113007), CDC-9 (PN 113011) & CDC-12 (PN 113013)

	PART NUMBERS	
	FACTORY INSTALLED	CUSTOMER INSTALLED
HEPA filter captures very fine particles.	140215	140215
Filter replacement	516305	516305
HEPA filter, pressure differential gauge assembly informs operator regarding filter cleanliness.	140221	140221
Leg extension kit raises collector so larger collection drum can be placed underneath.	140185	140185
Lid assembly for 55 gallon drum attaches securely to clean-out door. <b>(Page A65.)</b>	140155	140155
Manometer keeps operator informed regarding bag cleanliness.	140344	140398

**Photohelic cartridge cleaning** improves system performance, saves operator time.

140900

140900

### Photohelic Cleaning Components

Item	Description	PART #
1	Photohelic gauge	550074
2	Solenoid valve	516335
3	Timer board	585090
4	Diaphragm valve (2 required) (Not included; standard on collector)	516350

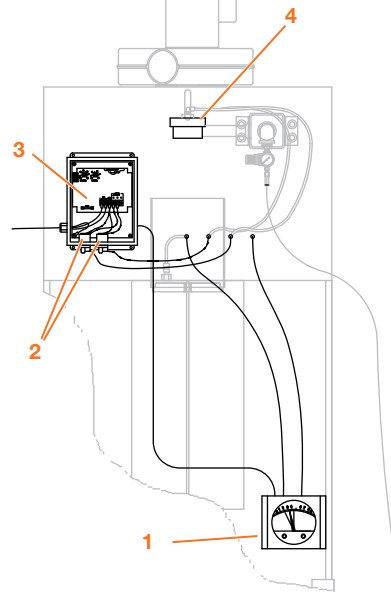

**Sound attenuator/exhaust damper** reduces noise in the work place.

Attenuator/damper for CDC-6

140361

140361

Attenuator/damper for CDC-9

140769

140769

Attenuator/damper for CDC-12

140680

140680

## SEM-2 Dust Collector Options

	PART NUMBERS	
	FACTORY INSTALLED	CUSTOMER INSTALLED

**Photohelic cartridge cleaning** improves system performance, saves operator time.

140810

140810

### Photohelic Cleaning Components

Item	Description	PART #
1	Photohelic gauge	550074
2	Diaphragm valve (2 required) (Not included; standard on collector)	516329
3	Solenoid valve	516335
4	Timer board	585090

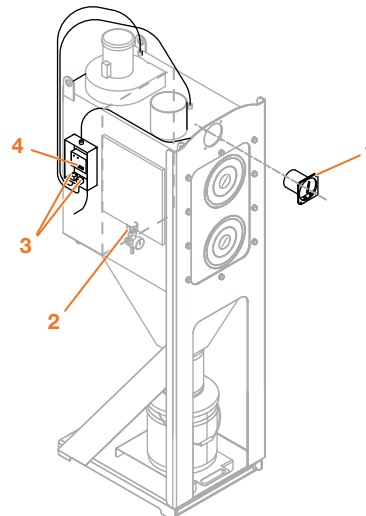

Sound attenuator/damper reduces noise in the work place.

140759

140759



## Options Details: Pro-Finish® Dust & Conveying Hose

### Dust and Conveying Hose Options

RECLAIMER CAPACITY	Description	400 CFM	600 CFM	900 CFM	1200 CFM
		PART NUMBERS			
	Dust hose for optional 3.5 ft <sup>3</sup> pressure vessel (I.D. x length)	515631 (6" x 25')	515631 (6" x 25')	516999 (10" x 15')	516999 (10" x 15')
	Conveying hose, heavy duty, with clamps, factory upgrade ** (I.D. x length)	140338 (4" x 9')	140338 (4" x 9')	140339 (6" x 12')	140339 (6" x 12')
	Conveying hose, heavy duty, with clamps, customer install (I.D. x length)	140354 (4" x 9')	140354 (4" x 9')	140355 (6" x 12')	140355 (6" x 12')
	Conveying hose, 4" I.D., heavy duty to length (Specify length)	515911	515911	515911	515911
	Conveying hose, 6" I.D., heavy duty to length (Specify length)	515921	515921	515921	515921
	Conveying hose, standard duty, for optional 3.5 ft <sup>3</sup> pressure vessel (I.D. x length)	516033 (4" x 15')	516033 (4" x 15')	516115 (6" x 18')	516115 (6" x 18')
	Conveying hose, heavy duty, for optional 3.5 ft <sup>3</sup> vessel, factory upgrade **	140613	140613	140614	140614
	Conveying hose, heavy duty, for optional 3.5 ft <sup>3</sup> vessel, customer install (I.D. x length)	140611 (4" x 18')	140611 (4" x 18')	140612 (6" x 20')	140612 (6" x 20')
	Hose clamp, heavy duty conveying hose	522953	522953	522963	522963

\*\* Not to be ordered as replacement hose



## Options Details: Pro-Finish® Reclaimers

### Reclaimer Options

	PART NUMBERS	
	FACTORY INSTALLED	CUSTOMER INSTALLED
<b>Ultrawear lining</b> extends reclaimer life by a factor of ten. (Not available with 400 CFM reclaimers.)		
600 CFM reclaimers	526183	NA
900-1200 CFM reclaimers	526193	NA
<b>Urethane lining</b> extends reclaimer life by a factor of five. (Not available with 400 CFM reclaimers.)		
600 CFM reclaimers	525861	NA
900-1200 CFM reclaimers	525891	NA
<b>Inlet wear plate</b> extends reclaimer life by shielding the reclaimer's most vulnerable area.		
400 CFM reclaimers	514471	514501
600 CFM reclaimers	514481	514511
900-1200 CFM reclaimers	514491	514521

### Reclaimer Wear Plate Components

CAPACITY (SCFM)	400	600	900/1200
<b>A</b> Rubber band	524871	524881	524891
<b>B</b> Bolt, 3/8" - 16 x 2" (3 required)	553892	553892	553892
<b>C</b> Metal band	761601	761611	761621
<b>D</b> Bolt, 3/8" - 16 x 1 1/2" (3 required)	551262	551262	551262
<b>E</b> Nut, 3/8" - 16	552542	552542	552542

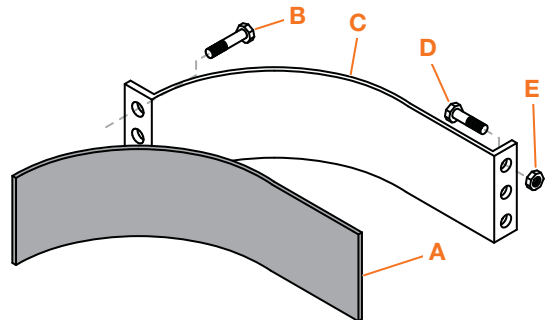



# Options Details: Pro-Finish® Pressure Blast Systems

## Pressure Blast System Options

**PART NUMBERS**  
**FACTORY INSTALLED**    **CUSTOMER INSTALLED**

**Blast hose assembly (1/2" top entry) takes weight off the operator's hands. (See page A49 for detail.)**    140878    140879

**Blast hose assembly (3/4", top entry) with 1/4" Di-Carb™ nozzle adds ease of handling, higher air/media capacity and longer nozzle life.**    140635    140634

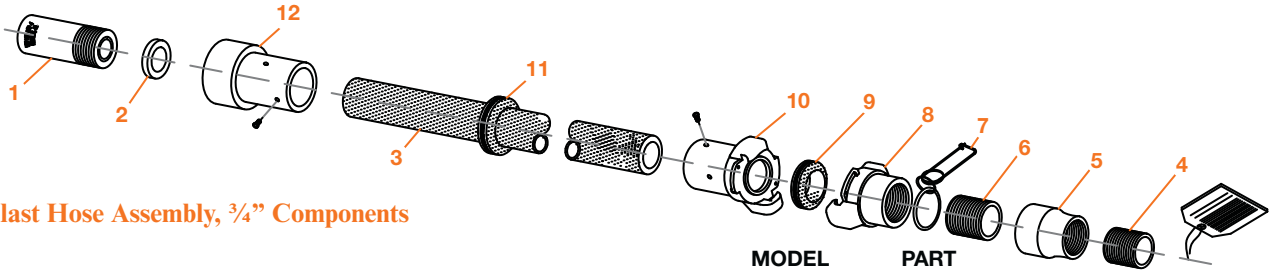

### Blast Hose Assembly, 3/4" Components

Item	Description	MODEL NUMBER	PART NUMBER
1	Nozzle, 1/4" Di-Carb™	DC3-4	501402
2	Nozzle washer, (10 pack)	NW-1	524062
3	Blast hose, 3/4" ID (specify length)	PBH-3/4	520812
4	Pipe nipple, 1" x close	-	546192
5	Bell reducer, 1 1/4" x 1"	-	545341
6	Pipe nipple, 1 1/4" x close	-	546292
7 †	Safety pin Δ	-	510511
8	Tank coupling, 1 1/4"	-	753262
9	Quick coupling washer (10 pack)	QCW	524032
	Quick coupling washer (25 pack)	QCW	525092
10	Quick coupling with washer and screw package	QC-3/4	751062
11	Grommet, blast hose, 1 1/2" x 1 5/8"	-	523331
12 †	Nozzle coupling	NC-3/4	753212

Δ **WARNINGS:** See page A55. † Essential component to prevent downtime

**Cone with 60° slope assures smooth flow of bridgeable media. (Only available with 1 ft³ pressure vessel.)**    505002    140060

**Constant pressure control assembly maintains desired pressure, improves blasting consistency.**    140523    Call

### Constant pressure control components

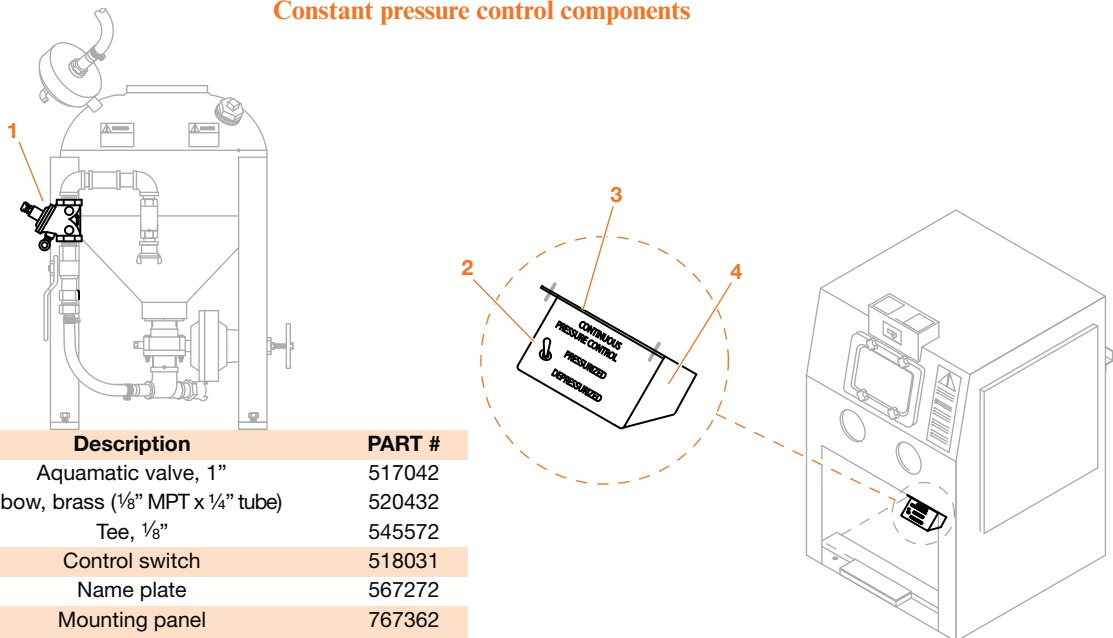

Item	Description	PART #
1	Aquamatic valve, 1" Elbow, brass (1/8" MPT x 1/4" tube) Tee, 1/8"	517042 520432 545572
2	Control switch	518031
3	Name plate	567272
4	Mounting panel Machine screw (2 required)	767362 552692

**Never use silica sand in any Empire equipment.**



# Options Details: Pro-Finish® Pressure Blast Systems

## Pressure Blast System Options (continued)

PART NUMBERS  
FACTORY INSTALLED    CUSTOMER INSTALLED

**Door sill package**, standard with Ergo-Blast models, catches dust and debris when a cabinet door is opened after blasting. (One package is required per door.)

(Part numbers shown below)

### Door sill Packages

### CABINET SIZES AND PART NUMBERS

	2636	3648	3660	3674	3696	4848	6060	60120
<b>Factory Installed Part #</b>	140725	140726	140726	140726	140726	140727	140728	140728
<b>Customer Installed Part #</b>	761551	761561	761561	761561	761561	761571	761581	761581

**Fine tuning package**, only available with optional automatic Sure-Flo® media regulator, enables the operator to adjust the media-to-air ratio from the work station.

140511    140512

**Fine tuning package with choke** enables the operator to clear clogs in the grit valve, as well as adjust the media/air mix, from the work station.

140509    140510

### Fine tuning components

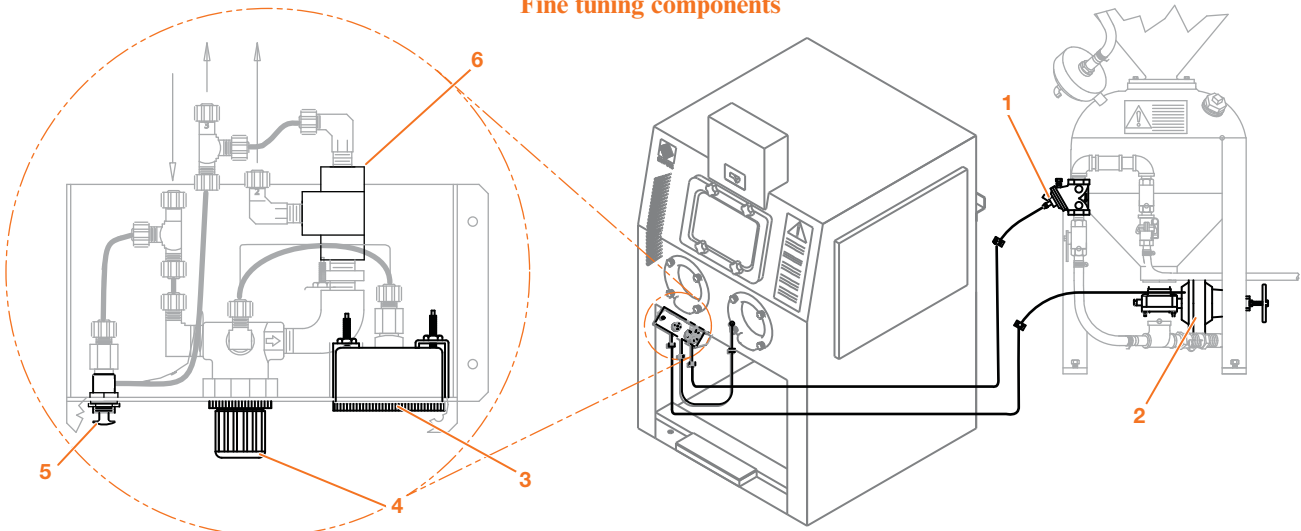

Item	Description	PART #
1	Aquamatic valve, 1"	517692
2	Sure-Flo valve, automatic	290215
3	Pressure gauge	550212
4	Regulator, relieving, 1/4"	517613
5	Air valve, push button	517221
6	Shuttle valve, 1/8"	518011

Never use silica sand in any Empire equipment.



# Options Details: Pro-Finish® Pressure Blast Systems

## Pressure Blast System Options (continued)

**PART NUMBERS**  
**FACTORY**    **CUSTOMER**  
**INSTALLED**   **INSTALLED**

**Media low-level sensor & indicator** warn when the media supply is low.

140381      Call

### Media Low Level Sensor & Indicator Components

Item	Description	PART #
1	Level sensor	600633
2	Indicator lamp (red)	532743

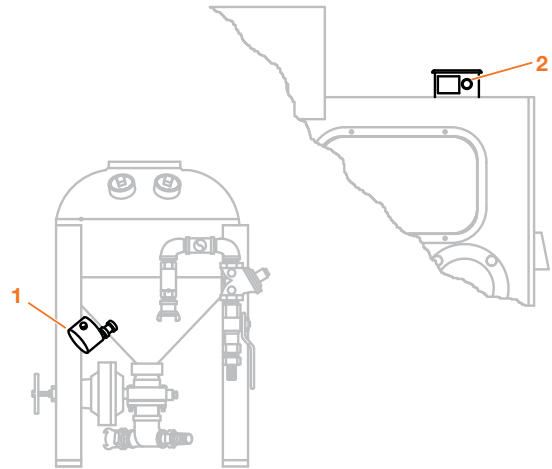

**Media regulator with aeration** promotes smooth flow of fine and light grit.

140374      140360

### Aerated Media Regulator Components

Item	Description	PART #
1	Tee, 1" NPT	545532
2	Hex bushing, 1" x 1/4" NPT	544482
3	Connector, brass, 1/4" MPT x 1/4" tube	521081
4	Nipple, 2 1/2"	546601
5	Upper ring	753581
6	Washer disc seal	524971
7	Washer inner-disc seal	524961
8	Regulator body	753601
9	Clamp knob	511041
10	Hex bushing, 1/4" x 1/8" NPT	544302
11	Clamp	753591
12	Metering orifice, 1/16"	762651
	Metering orifice, 3/32"	762661
	Metering orifice, 1/8"	762671
	Metering orifice, 5/32"	762681
	Metering orifice, 3/16"	762691
	Metering orifice, 7/32"	762701
	Metering orifice, 1/4"	762711
	Metering orifice, 3/8"	762731
13	Metering orifice, 5/16"	762721
13	Aeration disc	511031
14	O-ring	524941

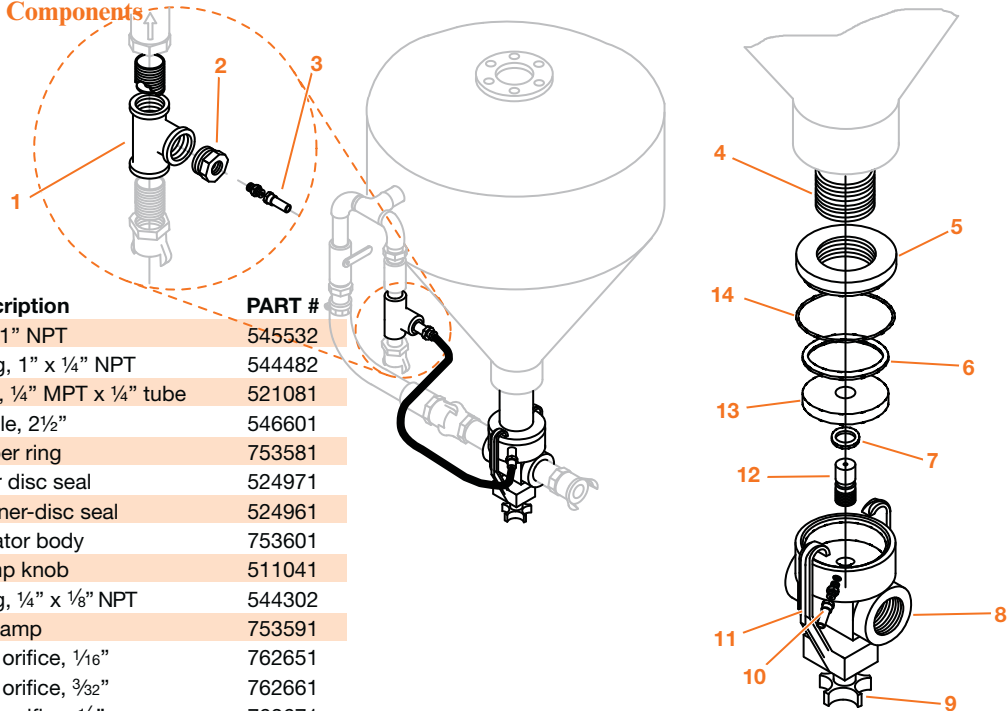



# Options Details: Pro-Finish® Pressure Blast Systems

## Pressure Blast System Options (continued)

PART NUMBERS  
**FACTORY INSTALLED**    **CUSTOMER INSTALLED**

**MG-78 CR exhaust valve** works in combination with the automatic Sure-Flo® media regulator to improve vessel refill with fine media.

290234    290232

**Boron restrictor** extends MG-78 CR valve life.

290184    290184

### MG-78 CR Exhaust Valve Components

Item	Description	PART #
1	Hose barb, 1"	520181
2	Reducer bushing, 1 1/4" MPT x 1" FPT	544512
3	Valve body	753332
4	Seat, valve ball (steel)	753412
5	Gasket, seat	524132
6	Valve ball	525322
7	Space washer, steel (1/2" ID x 2" OD x 1/4" thick)	553412
8	Spacer ring, outer	753402
9	Bolt, 3/8" - 16 x 2"	553982
	Lock washer, 3/8"	552762
10	Washer (1/2" ID x 2" OD x 1/16" thick)	552842
11	Spacer ring, inner	753392
12	Compression spring	516313
13	Tee, 1/4"	545502
14	Elbow, brass, 1/4" MPT x 1/4" tube (2 required)	520242
15	Nipple, 1/4" close	545912
16	Pipe bushing, 1/2" x 1/4"	544462
17	Pipe bushing, 3/4" x 1/2"	544472
18	Bolt, 1/2" - 13 x 1 3/4"	551962
19	Valve cover	751801
20	Diaphragm (2 per assembly)	523672
21	Pipe nipple, 1" CLOSE	546192
22	Screws, seat, 1/4" - 20 x 1/2" (pack of 3)	551122
<b>RESTRICTOR PARTS</b>		
23	Nozzle washer, NW-1 (pack of 10)	524062
24	Nozzle washer, NW-4 (pack of 10)	524082
25	Steel washer	552952
	Ceramic restrictor kit (standard)	290218
	Ceramic nozzle (standard)	502431
26	Boron carbide restrictor kit (customer upgrade)	502081
	Boron carbide restrictor kit (factory upgrade)	290184
	Restrictor repair kit	290183

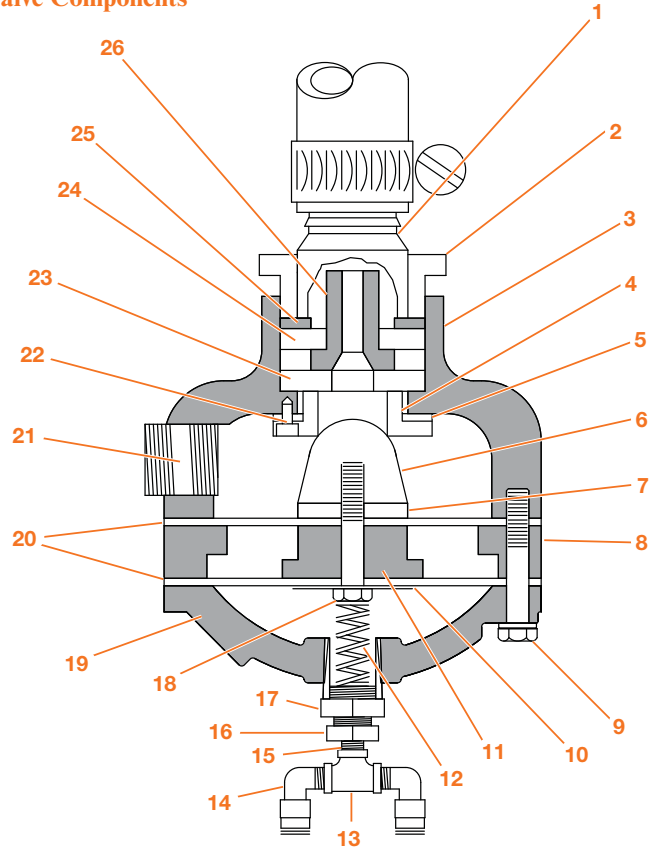

**Nozzle holder** frees the operator's hands to manipulate parts.

140401    140401

**Never use silica sand in any Empire equipment.**







# Options Details: Pro-Finish® Pressure Blast Systems

## Pressure Blast System Options (continued)

PART NUMBERS	
FACTORY INSTALLED	CUSTOMER INSTALLED

**Sure-Flo® automatic media regulator**, standard with FaStrip® models, supports Fine Tuning Packages for more precise media control.

290215      290215

### Automatic Sure-Flo® Media Regulator Components

Note: These fasteners are used two places to mount diaphragm body to Sure-Flo® valve.

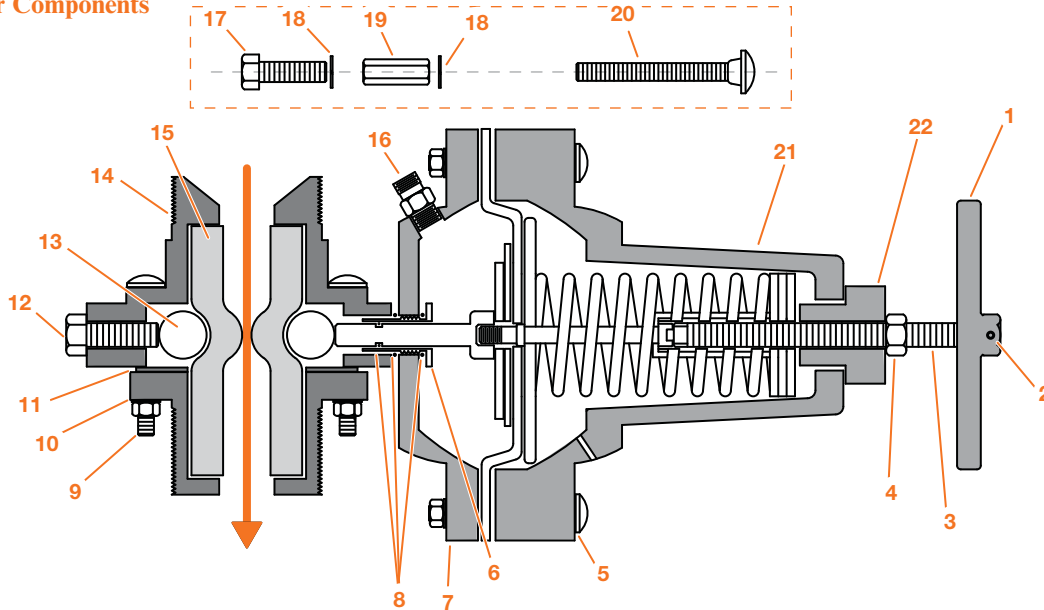

Item	Description	PART #
1	Handle assembly, 1/2" - 13, Auto Sure-Flo (after 5/84)	290217
	Handle assembly, 7/16" - 14 x 4" (before 5/84)	290211
	Handle only, 1/2" - 13	753622
2	Set screw, 1/2" - 13 x 1/2", nyloc	551732
3	Shaft handle	505802
4	Jam nut, 1/2" - 13	552672
5	Carriage bolt, 3/8" - 16 x 2 1/2"	552052
	Lock washer, 3/8" ID	552762
	Hex nut, 3/8" - 16	552542
6	Plunger guide	753462
7	Diaphragm cover	753112
8	O-ring kit (includes 2 for guide, 1 for plunger)	561422
9	Carriage bolt, 3/8" - 16 x 2 1/2"	552052
	Lock washer, 3/8" ID	552762
	Hex nut, 3/8" - 16	552542
10	Flange, 2" MPT	753292
11 †	Roller stop holder	753092
	Screw, 8 - 32 x 1/2" (2 per assembly)	551352
12	Bolt, 7/16" - 14 x 1 1/4"	552222
13 †	Pinch roller (2 per assembly)	753632
14	Valve body, 2" MPT	753692
15 *	Meter tube, 3/4" (See page A50 for choices.)	523592
16	Adapter, 1/4" NPT x 1/4" tube	521081
17	Bolt, 3/8" - 16 x 1 1/4" (2, Auto Sure-Flo)	551852
18	Lock washer, 3/8" ID	552762
19	Nut extension, 3/8" - 16 (2, Auto Sure-Flo)	552662
20	Carriage bolt, 3/8" - 16 x 2 1/2"	552052
21	Spring enclosure	753682
22	Spring tensioner	505822

### Spring & Diaphragm Detail (Part # 290296 includes items 23 through 28.)

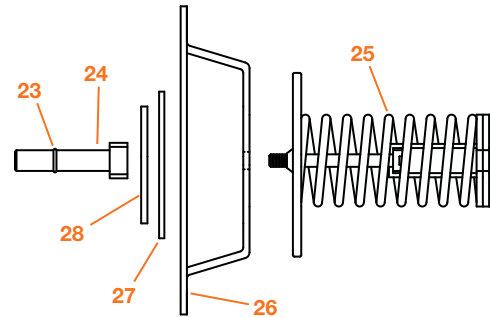

**WARNING:** Never attempt to disassemble the spring assembly in the automatic Sure-Flo. The spring is under tension and could cause injury to personnel.

Item	Description	PART #
23	O-ring kit (includes 2 for guide, 1 for plunger)	561422
24	Plunger with O-ring	505872
25	Spring assembly	290296
26	Diaphragm, raised (after 5/84)	525012
	Diaphragm, flat (before 5/84)	523662
27	Diaphragm gasket	525002
28	Washer, 1/2" ID	552842

\* Recommended spare part—Consumable wear item  
 † Essential component to prevent downtime

**Never use silica sand in any Empire equipment.**



# Options Details: Pro-Finish® Pressure Blast Systems

## Pressure Blast System Options (continued)

PART NUMBERS	
FACTORY INSTALLED	CUSTOMER INSTALLED

Vessel, 3.5 cubic-foot pressure assembly, reduces time required for media refills.  
 Vessel for 400 and 600 CFM applications  
 Vessel for 900 and 1200 CFM applications  
 Sight glass for 3.5 cubic-foot pressure vessel

140609	140607
140610	140608
545493	545493

### Pressure Vessel (3.5 ft<sup>3</sup>) Components

Item	Description	PART #
1	Tee, 1" x 1" x 2"	545822
2	Aquamatic valve, 1"	517042
3	Ball valve, 1"	518492
4	MG-78 exhaust valve	290182
5	Hose barb	520181
6	Exhaust hose assembly	140691
7	Access window	526231
8	Hopper assembly, 3.5 cubic foot	290475
9	Gasket, ¼" x 1", closed cell	523622
10	Gasket, 1" x 1½"	523641
11	O-ring	523872
12	6" Plunger	525072
13	Sure-Flo® media regulator, automatic	290215

See page A46 for hose requirements and hose options.

See page A72 for optional sight glass (PN 545493).

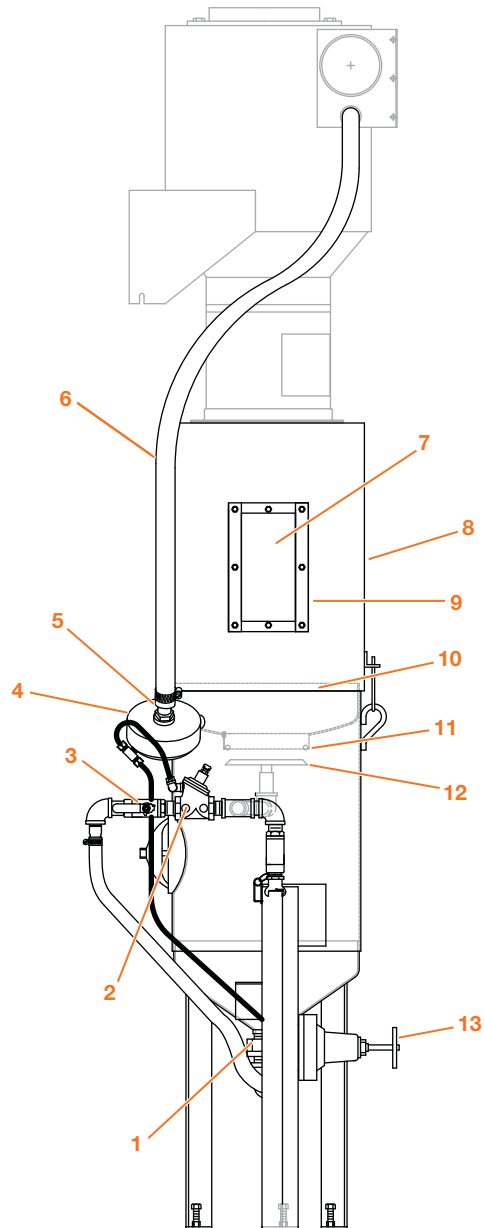



# Options Details: Pro-Finish® Suction Blast Systems

## Suction Blast System Options

	PART NUMBERS	
	FACTORY INSTALLED	CUSTOMER INSTALLED
<b>Gun holder</b> frees the operator's hands to manipulate parts.	140400	140400
<b>Gun package supporting a second gun</b> expands the work envelope.	140347	140351
<b>Gun package supporting two additional guns</b> for total of three.	140348	140352
<b>Gun package supporting three additional guns</b> for total of four.	140349	140353
<b>Media storage hopper</b> with 4.5 cubic-foot capacity supports multiple blast guns.	140487	140487
<b>Pipe string</b> with 1" ID supplies additional air for multi-gun packages.	140310	140310

### Components for Multiple Gun Packages

Item	Description	PART #
1	Blast hose, 5/8" (Specify length)	520802
2	Screw	551042
3	Plug	510121
4	SAR-2 regulator body	753351
4	SAR-2 assembly (includes 2 through 5)	290156
5	Pipe nipple, 5"	546742
6	Hopper assembly, multi-gun, 4 outlet	140487
7	Gasket, reclaimers/hopper	524371
8	Manifold	504025
9	Ball valve, 1/2"	518472
10	Air hose, 1/2" (Specify length)	520861
11	Air-hose assembly, 1"	140304
12	Arm extension	510731
13	Knuckle assembly	560231
	Fixed-gun holder assembly (includes 12 & 13)	140400
14	MH-2 gun, short handle, 5/16" jet	505541
15	Pipe-string assembly included with customer installed (See page A47 for details.)	140280

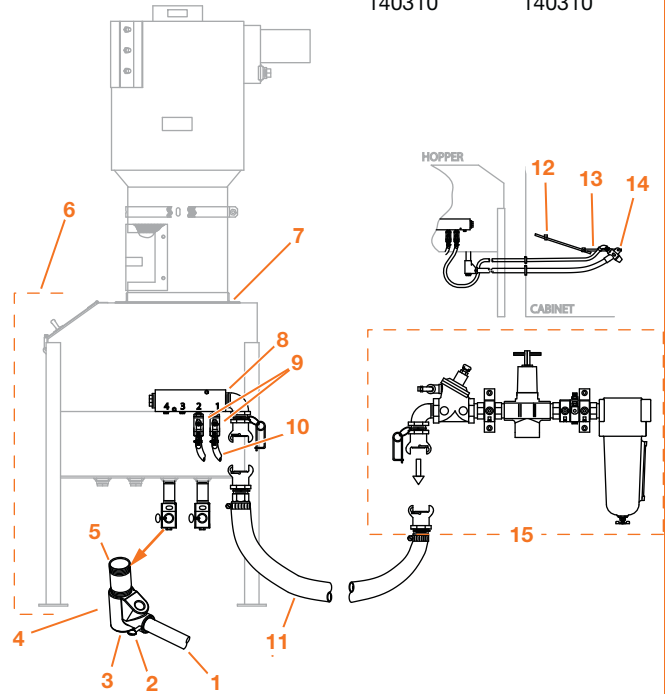

**KLEEN™ package** prevents dust from dropping onto the floor when cabinet doors are opened and returns pressurized media to the cabinet in the event that a blast nozzle plugs.

- 2636 cabinets
- 3648, 3660, 3674 and 3696 cabinets
- 4848 cabinets
- 6060 and 60120 cabinets

140356	140391
140357	140392
140358	140393
140359	140394

**Suction conversion kit** includes parts to switch cabinets from pressure to suction.

NA 140396

### Suction Conversion Kit Components

Item	Description	PART #
1	Storage hopper	760751
2	Gasket, reclaimers to hopper	524371
3	Plug	544122
4	MH-2 suction gun with 5/16" ceramic nozzle	505481
5	Air hose	522861
6	Grommet, 3/4" ID x 1 3/8" OD	523921
7	Grommet, 1" ID x 1 3/4" OD	523931
8	Blast hose, 5/8"	520802
9	Media regulator, SAR-2	290156

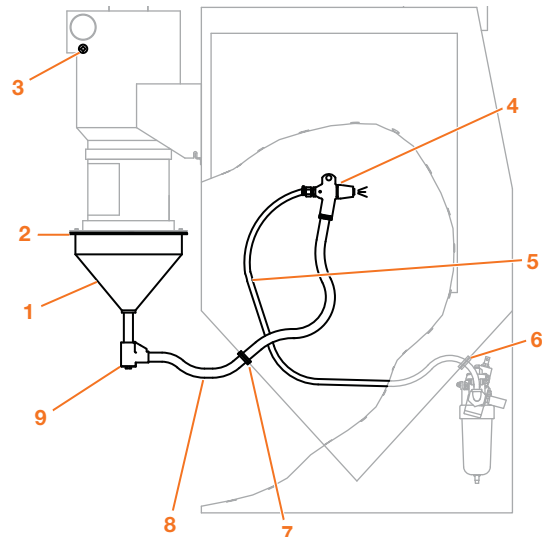

Never use silica sand in any Empire equipment.